

MWPAAC Engineering & Planning Subcommittee

**FINAL DRAFT**

**Design and Engineering Standards**



## REGIONAL I/I CONTROL PROGRAM

### STANDARDS, PROCEDURES & POLICIES FOR I/I REDUCTION PROJECTS FINAL DRAFT INTRODUCTION TO ENGINEERING STANDARDS

#### Purpose and Background

Based upon discussions with King County staff, the Local Agencies and regional I/I programs across the nation, it has been determined that factors contributing to I/I in the local and regional wastewater systems include improper construction practices and materials; lack of adequate inspection and testing prior to acceptance of a new and rehabilitated sections of sewer; improper system maintenance; and inadequate enforcement of existing ordinances.

This section presents standards, guidelines and procedures for future King County and Local Agency sewer system planning and design that have been developed to focus on correcting shortcomings in design, construction, inspection and testing that have been responsible for I/I. The standards, guidelines and procedures address only those features of sewer systems associated with I/I. They are intended to augment and emphasize standards published by the individual Local Agencies that outline design requirements for overall sewer system design, construction and rehabilitation.

#### Contributing I/I Factors

Infiltration and inflow are extraneous flows in separated sanitary sewer systems. Infiltration is groundwater that enters buried sewers and service connections by way of defective sewer main elements such as leaky connections of pipes to manholes, broken or separated pipe joints, root intrusion, cracked or crushed pipe, leaky rehabilitation improvements and leaking sewer lines that are abandoned but still connected to the system (see diagram):

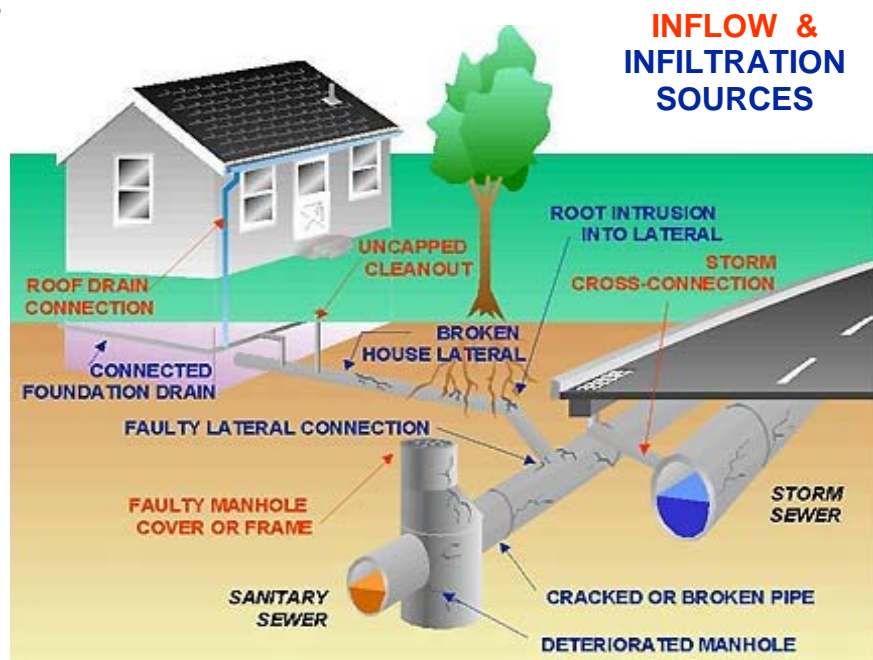

Inflow is surface water that enters the sanitary sewer system by direct connections from roof drains, area drains, catch-basins and unimproved surface drainage. Groundwater sources connected to the system including footing drains and sump pumps, and surface water entering the system through manhole covers are also sources of inflow (see diagram).

The following are key factors contributing to impairment of sewer systems' structural abilities, resulting in infiltration and/or inflow:

- Sewer mains, laterals and side sewers that are not properly supported are subject to vertical displacements over time, causing joints to open and pipeline trenches to settle, producing cracks or breaks in sections of the pipe.
- Manholes constructed in wet ground become recipients of groundwater if the exterior walls are not adequately sealed to make joints and connections watertight.
- Structural failure of sewer pipes allows groundwater to enter the system at the point of connection to manholes. Deep cuts and poor ground conditions often result in a larger than necessary excavation, leading to unequal settlement if uniform support is not provided for the pipe and manhole. Inadequate support often causes failure of the pipe in shear at the manhole and provides a point of entry for groundwater.
- Materials must be appropriate for the ground conditions present. Pipeline failures often occur due to the misuse of materials.
- Wyes and tees not properly plugged with a manufacturer's watertight plug, snugly fit and firmly secured, until services are installed and connected can be a source of I/I. Improperly connected service lines, unplugged wyes and tees, and broken plugs allow groundwater infiltration.
- Root systems of plants and trees seeking underground water supplies for nourishment will grow into a sewer through deteriorated and non-gasketed joints or other openings. Groundwater will follow the path of the roots into the sewer. Root intrusion also impedes the normal flow in the pipe, and can eventually stop the flow entirely.
- Manholes that are subject to inundation or located in the path of surface water flow can contribute significant quantities of runoff to the sanitary sewer system.

Recognizing past situations that have allowed extraneous flows to enter the system and establishing standards to prevent these deficiencies on future projects can greatly reduce future I/I. Equally important is ensuring that the standards are followed during construction. Even when adequate standards are in place and used for sewer system design, a lack of inspection and testing during construction allows deficiencies in the system that let extraneous flows enter the system. The standards, guidelines and procedures in this section address testing and inspection requirements for sewer system construction as well as requirements for sewer system planning and design.

### **Development of Standards, Guidelines and Procedures**

The process of developing the Standards, Guidelines and Procedures was a collaborative effort among King County, the Local Agencies and the Earth Tech Consultant Team that spanned several years, as described in the Introduction to this report.

The E&P Subcommittee developed the initial draft standards and policies while considering cost, experience and feasibility factors. In discussing the level of control that should be included in the standards, the group determined that the approach to requiring new and/or different engineering techniques, procedures and policies would be most successful if introduced to the Region's Local Agencies in relatively small, incremental steps. The Subcommittee made this decision based upon financial and political realities. For this reason, the group often opted for the specific alternative of each Standard that required the least risk or financial impact. The group agreed that some alternatives should be considered voluntary Guidelines instead of mandatory Standards. A working draft set of Standards, Guidelines, Procedures and Policies,

dated October 21, 2002 resulted from this effort. A summary of the original and rewritten standards is included in Appendix A.

The E&P Subcommittee decided to apply the working draft Standards, Guidelines, Procedures and Policies to the pilot projects, in order to test their effectiveness and the impacts on staff time and the Local Agency's resources. Following completion of the pilot project construction, the Standards, Procedures and Policies were revisited by the Earth Tech Team to review their effectiveness, incorporate the lessons learned during the project design and construction, and make recommendations for any proposed changes to the documents. The proposed changes were presented and reviewed with the E&P Subcommittee, and a final draft set of Regional I/I Control Standards and Procedures was established. A summary of the proposed changes to the working draft and the Subcommittee's recommendations and accepted changes is included in Appendix A. The Final Draft Standards and Procedures appear below.

### **Organization of Standards and Guidelines**

The standards and guidelines are divided into the following three major categories:

- **Planning Standards and Guidelines (PS)**– The planning standards and guidelines provide criteria to be followed during the planning phase of sewer projects and I/I investigations.
- **Public Facilities (PUB)**– The public facility standards and guidelines provide requirements for sanitary sewer systems that will be owned, operated and maintained by King County or a Local Agency. These systems include sewers to be constructed within public rights-of-way and developer extensions constructed within easements that eventually will be transferred to a Local Agency. Categories here include design and construction standards, testing standards, inspection standards and warranty requirements.
- **Private Facilities (PRV)**– The public facility standards and guidelines provide requirements for privately owned sanitary sewers. It addresses the segments of sanitary side sewers and laterals belonging to the property owners being served. Categories here include design and construction standards, testing standards, inspection standards and warranty requirements.

Separate standards and procedures are provided for new construction and rehabilitation projects. New construction includes the addition of sanitary sewer infrastructure in areas that do not currently have sewer service, as well as the replacement of existing systems. Rehabilitation projects include improvements to existing sanitary sewer systems, including collection mains, manholes and side sewers. Rehabilitation techniques such as cured-in-place liners, pipe bursting, slip-lining and manhole liners fall into this category.

### **Outline of Individual Standards and Procedures**

Each standard or procedure in this document is listed on a separate sheet. While some standards originally offered several alternatives to provide a variety of levels of I/I control with considerations for impact to the Local Agencies, the E&P Subcommittee has narrowed these alternatives to one recommendation per standard, shown in this section. Each standard consists of the following:

- ***I/I Control Standard Title*** – A brief name of the Standard.
- ***I/I Control Measure Description*** – A description of why the Standard is being proposed; essentially what I/I source is being targeted.

- **Standard/Guideline** – This describes the Standard/Guideline in sufficient detail for engineers and Local Agency representatives to compare the intent with existing standards.
- **Potential Local Agency Impacts** – This indicates the potential impacts on Local Agencies adopting the standard. Impacts may include additional staffing requirements and impacts on Local Agency procedures such as record keeping, inspections, maintenance, equipment, and other elements of daily operations. Elements of the Standards that could bring added or reduced cost to the normal processes of an Local Agency are listed. Due to the variability between Local Agencies, no specific dollar amounts are presented.
- **Potential King County Impacts** – This indicates the potential impacts on King County of adopting the Standard. Impacts may include additional staffing requirements and impacts on County procedures, record keeping, inspections, maintenance, equipment, and other elements of daily operations by Department of Natural Resources staff. Elements of the Standards that could bring added or reduced cost to the normal County processes are listed.
- **Potential Private Property/Ratepayer Impacts** – Many of the Standards have the potential to impact private property owners or affect sewer rates. These impacts may include increased maintenance responsibilities for property owners, construction impacts, and cost increases or reductions.

### **Standard Details**

The Standards and Guidelines also include a set of standard details that outline specific requirements for the construction of manholes, sewer mains, and side sewers to help prevent I/I from entering a new sewer system. The details only address specific features of sewer construction that impact I/I control, and are intended to augment current Local Agency standard details for sewer construction.

Similar to the Standards and Guidelines, the standard details were tested during the pilot project design and construction, and later revisited by the Earth Tech Team and reviewed by the E&P Subcommittee for any final revisions. A summary of the proposed changes to the working draft details and the Subcommittee's recommendations and accepted changes is included in Appendix A.

### **Summary of Standards and Guidelines**

The following table provides a summary and brief description of the final draft Standards and Guidelines. A total of 40 standards/guidelines were incorporated into the final draft, with 28 being accepted by the Subcommittee as standards and 12 being accepted as guidelines.

## Regional I/I Control Program

## Summary of Listed Design Standards &amp; Guidelines

Standard/Guideline Number & Title	Standard	Guideline	New Projects ONLY	Rehabilitation Projects ONLY	Both New & Rehabilitation Projects
PS-1: Storm Drainage Connections to the Sanitary Sewer	√				√
PS-2: Design Capacity for Pipeline Rehabilitation Projects	√			√	
PS-3: Visual Inspection of Manholes for SSES Investigations		√		√	
PS-4: Closed Circuit Television (CCTV) Inspection of Sewers for SSES Investigation		√		√	
PS-5: Smoke Testing for SSES Investigations		√		√	
PS-6: Dye Testing for SSES Investigations		√		√	
PS-7: Modeling and Engineering Analysis		√			√
PUB-1: Connections to Existing System	√				√
PUB-2: Pipe Anchoring	√				√
PUB-3: Manhole Location	√				√
PUB-4: Manhole Size	√				√
PUB-5: Manhole Joints	√				√
PUB-6: Side Sewer Connection Location and Taps	√				√
PUB-7: Sewer System Design	√				√
PUB-8: Abandonment Requirements	√				√
PUB-9: Pipe Rehabilitation Methods	√			√	
PUB-10: Manhole Rehabilitation		√		√	
PUB-11: Spot Repairs		√		√	
PUB-12: Manhole Leveling Rings	√				√
PUB-13: Manhole Lids/Inserts	√			√	
PUB-14: Root Intrusion	√			√	
PUB-15: Pipeline Leak Testing	√				√
PUB-16: Manhole Leak Inspection	√				√
PUB-17: CCTV Inspection	√				√
PUB-18: Inspection of Pipe Installation and Backfill	√				√
PUB-19: Product Specific Inspection	√				√
PUB-20: Certification, Warranty and Qualifications		√			√
PRV-1: Pipe Protection – Depth of Cover		√			√
PRV-2: Allowable Connections to Side	√				√

Standard/Guideline Number & Title	Standard	Guideline	New Projects ONLY	Rehabilitation Projects ONLY	Both New & Rehabilitation Projects
Sewers					
PRV-3: Pipe Zone Bedding and Trench Backfill		√			√
PRV-4: Pipe Materials		√			√
PRV-5: Inspection Wyes/Cleanouts	√				√
PRV-6: Lateral and Side Sewer Rehabilitation Methods		√		√	
PRV-7: Spot Repairs	√			√	
PRV-8: Root Intrusion	√			√	
PRV-9: Side Sewer/Lateral Leak Testing	√				√
PRV-10: Sanitary Side Sewer CCTV Requirements	√				√
PRV-11: Product Specific Inspection	√				√
PRV-12: Product Specific Certification	√				√
PRV-13: Bonding and Warranty Inspection	√				√
<b>TOTAL ITEMS:</b>	<b>28</b>	<b>12</b>	<b>0</b>	<b>13</b>	<b>27</b>

**Table of Contents: Standards**

- B-8:** Individual Design Standards: Planning Standards (PS)
- B-19:** Public Facilities (PUB) Standards
- B-42:** Private Facilities (PRV) Standards
- B-60:** Standard Detail Drawings

**I/I CONTROL STANDARD TITLE: Storm Drainage Connections to the Sanitary Sewer**

**STANDARD NO. PS-1**

**I/I CONTROL MEASURE ISSUE:**

Direct connection of storm water collection systems to the sanitary sewer reduces the capacity of the collection system and increases surcharging potential of the pipe, which can contribute to sewer deterioration and increase the potential for pipeline collapse. Some agencies allow surface water runoff collected from areas subject to high pollutant loading to discharge to the sanitary sewer. Numerous connections of this type can overload both the Local Agency sanitary sewer collection system and the regional conveyance system.

**STANDARD**

⊕ No storm drainage connections shall be made to the sanitary sewer system unless approved by the Local Agency first and then by King County, and only under special circumstances. The discharges shall be defined by discharge permit, contract or other such document.

**POTENTIAL LOCAL AGENCY IMPACTS**

- ⊕ Provisions for water quality treatment from surface water collection areas subject to high pollutant loading that the agency may have previously connected to the sanitary sewer will need to be addressed.
- ⊕ Requests to connect storm water collection areas to the sanitary sewer will have to be reviewed for conformance with the special circumstances negotiated between the Local Agencies and King County.
- ⊕ Special fee structures may be adopted for connection of storm drainage sources to the sanitary sewer.

**POTENTIAL KING COUNTY IMPACTS**

⊕ King County and the Local Agencies will need to determine the special circumstances under which a storm drainage collection source can be connected to the sanitary sewer system.

**POTENTIAL PRIVATE PROPERTY/RATEPAYER IMPACTS**

⊕ No impact.

**I/I CONTROL STANDARD TITLE: Design Capacity for Pipeline Rehabilitation Projects**

**STANDARD NO. PS-2**

**I/I CONTROL MEASURE ISSUE:**

Many pipeline rehabilitation techniques for I/I control involve some loss in the hydraulic capacity of the system because the technique reduces the effective internal diameter of the pipe. Hydraulic capacity loss can range from moderate for techniques such as CIPP to high for techniques such as sliplining. Surcharging and sanitary sewer overflows can result if the hydraulic capacity is reduced below the required service capacity of the line.

**STANDARD**

⊕ The design of pipeline rehabilitation projects for I/I control shall consider any loss in the hydraulic capacity of the system resulting from a decrease in the effective internal diameter of a pipeline. A Professional Civil Engineer shall verify that the rehabilitated pipe maintains the required hydraulic capacity to service peak demand flow projections for the area tributary to the pipeline.

**POTENTIAL LOCAL AGENCY IMPACTS**

⊕ Agencies will need to verify that the project designer has addressed the hydraulic capacity of the pipeline.

**POTENTIAL KING COUNTY IMPACTS**

⊕ King County will need to verify that the project designer has addressed the hydraulic capacity of the pipeline.

**POTENTIAL PRIVATE PROPERTY/RATEPAYER IMPACTS**

⊕ No impact.

## **I/I CONTROL GUIDELINE TITLE: Visual Inspection of Manholes for SSES Investigations**

### **GUIDELINE NO. PS-3**

#### **I/I CONTROL MEASURE ISSUE:**

Manhole inspections are one of the most important efforts of an SSES investigation because manholes can account for up to 50 percent of the I/I entering a sanitary sewer system. The inspection provides a means for viewing the manhole internally to assist in:

- Determining whether the cover is subject to ponding or surface water runoff.
- Inspecting for internal leaks.
- Analyzing structural deficiencies in the manhole structure.
- Estimating I/I quantities in the manhole.

Investigation of the internal condition of a manhole should be conducted from the inside of the manhole. Performing the investigation only from the surface and failing to thoroughly check the manhole interior commonly results in an inadequate inspection. Leaks around taps in the manhole are often confused with flow from the tap itself. If not closely inspected, leaks on the floor, in the channel, and around the pipe seals are often misidentified as eddies in the normal pipe flow.

#### **GUIDELINE**

⊕ Visual inspection of manholes shall be performed by experienced personnel trained in the proper safety measures for performing the inspection including, but not limited to, confined space entry and traffic control measures. It is recommended that the visual inspection be performed during the wet season when surrounding soils are fully saturated. Results of the manhole inspections shall be documented on a standard form which contains the following information:

- Manhole identification or reference number and street location.
- The date of the inspection.
- Name of the inspector.
- Pavement surface type and condition.
- Cover information including size, number of pick holes, gasket condition, if present, and whether the cover is locking or not.
- Frame information including size, grade, condition and presence and condition of an internal boot.
- Chimney information including material and condition, diameter, height, seal condition at cone or top slab, presence and location of manhole steps, and evidence of infiltration.
- Cone information including type and condition, seal at barrel and evidence of infiltration.
- Barrel information including type, lateral locations, diameter and condition, seal at bench and bottom slab, and evidence of infiltration. Location and size of cracks and leak locations shall be documented.
- Condition of channel and bench concrete and location of infiltration at the flow line and bench.
- Presence, location and condition of drop connections.
- Whether the manhole cover is depressed below the adjacent surface grade and whether its location makes it subject to surface water flows or ponding.
- Significant site features that may affect rehabilitation access or methods, including whether the manhole is located on private property or is located near sensitive habitat.

Investigation of the internal manhole condition shall be conducted from inside the manhole if I/I is present in the manhole. Manhole inspection results shall be archived by the Local Agency.

**POTENTIAL LOCAL AGENCY IMPACTS**

- ⊕ Training and upgrading of staffing skills to perform the manhole inspections and interpret results, if not contracted with outside vendors.
- ⊕ Additional staff resources (FTEs) may be required.
- ⊕ Additional staff time for conducting inspections, interpreting results, reporting and archiving of data.

**POTENTIAL KING COUNTY IMPACTS**

- ⊕ Training and upgrading of staffing skills to perform the manhole inspections and interpret results, if not contracted with outside vendors.
- ⊕ Additional staff resources (FTEs) may be required.
- ⊕ Additional staff time for conducting inspections, interpreting results, reporting and archiving of data.

**POTENTIAL PRIVATE PROPERTY/RATEPAYER IMPACTS**

- ⊕ No impacts.

## **I/I CONTROL GUIDELINE TITLE: Closed Circuit Television (CCTV) Inspection of Sewers for SSES Investigations**

### **GUIDELINE NO. PS-4**

#### **I/I CONTROL MEASURE ISSUE:**

CCTV inspection during a sewer system evaluation survey provides a safe, low-cost and rapid means for viewing the sewer line internally to assist in:

- Determining the physical condition of pipe joints.
- Analyzing structural deficiencies and corrosion in pipelines.
- Identifying sources of I/I.
- Estimating quantity of infiltration.
- Identifying changes in the sewer from the last CCTV inspection.

#### **GUIDELINE**

⊕ CCTV inspection of sewers for an SSES investigation shall include a complete television inspection of the sewer main and may include laterals and side sewers that connect to the main. It is recommended that the CCTV inspection be performed during the wet season when surrounding soils are fully saturated. The decision to CCTV inspect laterals and side sewers shall be based on evidence that a significant source of the I/I originates from the laterals or side sewers. The factors that shall be considered include:

- Flow monitoring data that suggests rapid infiltration.
- Lack of I/I sources identified from CCTV inspection of the sewer main or smoke testing.

Sewer cleaning shall be performed before beginning television inspection of sewer mains, laterals and side sewers. Television inspection shall be accomplished using a closed-circuit system specifically designed for sewer inspections. For each pipeline inspected, records shall be collected on both videotape and on a field form. The videotape shall include the date of the inspection and a brief narrative description of the pipeline being inspected (manhole to manhole run, or service address) and discuss each defect that is observed. Field forms for sewer main inspections shall contain the following information:

- The date of the inspection.
- Name of CCTV crew members and their company or agency.
- The reason for the inspection.
- The location of the pipeline and the upstream and downstream manhole numbers.
- The direction of the camera's travel.
- The pipe size, type, pipe joint length, and overall footage of the inspected sewer.
- The location and a description of each service connection.
- A description of each defect observed and its distance from the point at which the viewing began.
- Severity of I/I at each defect location.

Field forms for lateral and side sewer inspections shall contain the following information:

- The date of the inspection.
- Name of CCTV crew members and their company or agency.
- The reason for the inspection.
- The service address.
- The pipe size, type, pipe joint length, and overall footage of the inspected lateral/side sewer.
- A description of each defect observed and its distance from the point at which the viewing began.
- Severity of I/I at each defect location.
- The location and a description of any observed connections to the lateral/side sewer.

Field forms and videotape of inspections shall be archived by the Local Agency so that they may be compared to subsequent CCTV inspections that are performed on the same portions of the line. Digital

footage of the CCTV inspection is an acceptable alternative to videotaped footage.

**POTENTIAL LOCAL AGENCY IMPACTS**

- ⊕ Training and upgrading of staffing skills to perform the CCTV inspections and interpret results, if not contracted with outside vendors.
- ⊕ Additional staff resources (FTEs) may be required.
- ⊕ Acquisition of CCTV inspection equipment and vehicles, or contracting with outside vendors.
- ⊕ Additional staff time for conducting inspections, interpreting results, reporting and archiving of data.
- ⊕ Additional cost for CCTV of laterals/side sewers.

**POTENTIAL KING COUNTY IMPACTS**

- ⊕ Training and upgrading of staffing skills to perform the CCTV inspections and interpret results, if not contracted with outside vendors.
- ⊕ Additional staff resources (FTEs) may be required.
- ⊕ Acquisition of additional CCTV inspection equipment and vehicles, or contracting with outside vendors.
- ⊕ Additional staff time for conducting inspections, interpreting results, reporting and archiving of data.

**POTENTIAL PRIVATE PROPERTY/RATEPAYER IMPACTS**

- ⊕ No impact.

## I/I CONTROL GUIDELINE TITLE: **Smoke Testing for SSES Investigations**

### GUIDELINE NO. **PS-5**

#### **I/I CONTROL MEASURE ISSUE:**

Smoke testing is the process of blowing a nontoxic smoke made from mineral oil at low pressure into the sewer system. Smoke testing provides a low-cost and rapid means for determining direct connections of inflow and rainfall-induced infiltration sources, such as:

- Roof drains
- Foundation drains
- Catch basins
- Area drains
- Abandoned building sewers
- Uncapped cleanouts
- Illegal connections
- Storm sewer cross connections

#### **GUIDELINE**

☛ Smoke testing for SSES investigations shall be performed by experienced personnel who know the effects of groundwater table, frozen ground, wind, rain, trapped service connections and snow cover on the test findings. Smoke used for the testing shall be non-toxic, odorless and non-staining. Blower capacity shall be determined based on the size of area to be tested, but in no case shall it be less than 1,750 cfm. The vacuum effect of flowing water drawing smoke downstream shall be taken into account. Police and fire departments shall be notified daily of test locations, and residents shall be notified in advance of the testing by a written testing notice. Residents shall also be informed individually on the day of testing by personnel having proper identification. The following chronological steps shall be used for smoke testing:

- Isolate the sewer main line to be tested with plugging up to 400 feet at a time noting any surcharged line sections. Smoke will not pass through a flooded section.
- Prepare a basic smoke sketch of the area being tested including location, date and the name of the company or agency and personnel performing the test.
- Commence smoke testing using one blower at each manhole and enough smoke bombs to ensure smoke travels throughout the entire test section. Smoke shall be continuously generated while visual inspection and photography are in progress.
- Visually inspect the entire area by walking around front and back yards and around buildings. Watch for smoke leaks; typical sources are roof leaders, area drains, foundation drains, house foundations, holes in the ground over the sewer or services, areas around manholes, and catch basins. Roof vents are not to be considered as smoke leaks.
- Document whether or not smoke is observed to be discharging through the roof vents for each house and building included in the test area.
- Photograph all smoke leaks.
- Show the location of each leak on a sketch. Include the photograph number and compass directions taken, and a description of the leak including address. Provide dimensions to the leak from at least two easily identified site features and the estimated area (square footage) and surface type (i.e., grass, pavement, etc.) drained by the leak.
- Photographs shall show the maximum amount of smoke emitted from the leak and the exact source of the leak. Photographs shall be taken from far enough back to provide a physical reference to the location of the smoke. They shall be numbered consecutively to ensure leaks can be identified at a later date.

**POTENTIAL LOCAL AGENCY IMPACTS**

- ✦ Time and resources to conduct smoke testing, if not already part of agency procedures.
- ✦ Acquisition of smoke testing equipment, if not already owned.
- ✦ Cost for additional staff workload, or contract with outside vendor.

**POTENTIAL KING COUNTY IMPACTS**

- ✦ Cost for additional staff workload, and contract with outside vendor.

**POTENTIAL PRIVATE PROPERTY/RATEPAYER IMPACTS**

- ✦ Identified defects and illicit connections on private property may need to be corrected by the property owner.

## I/I CONTROL GUIDELINE TITLE: Dye Testing for SSES Investigations

### GUIDELINE NO. PS-6

#### I/I CONTROL MEASURE ISSUE:

Dye testing is a rainfall simulation technique used to identify specific defects that can contribute I/I during rainfall or snowmelt. Dye testing can also be effective in quantifying the amount of I/I that can enter a section of sewer or specific defect under a controlled runoff situation. Depending on the sources of I/I to be identified and the configuration of the runoff situation being simulated, the procedures for dye testing differ. Five examples of dye testing situations are as follows:

- **Determining Conditions Caused by Storm Drains**—Storm drains that parallel or cross sanitary sewer pipes and have an invert elevation higher than the crown elevation of the sanitary sewer can be a source of rainfall-induced infiltration or inflow. They are inflow sources if there are cross connections between the storm drain and the sanitary sewer; they are infiltration sources if stormwater can exfiltrate from them, percolate through soil, and enter the sanitary sewer through pipe or joint defects.
- **Determining Conditions Caused by Stream or Ditch Sections**—Streams and stormwater ditches are inflow sources if there are cross connections between them and the sanitary sewer; they are infiltration sources if the surface water can percolate through soil and enter the sanitary sewer through pipe or joint defects.
- **Identifying I/I Sources from Private Property**—Roof leaders; basement, yard and area drains; foundation drains; abandoned building sewers; and faulty connections are sources of private property defects that can be identified by dye testing.
- **Identifying Structurally Damaged Manholes**—Dye testing can be used to verify structurally damaged manholes that leak when subjected to flooding or when groundwater elevations are high.
- **Verifying Sources Found by Other Testing Means**—Dye testing can verify suspected sources of I/I identified in a visual survey or smoke testing study. Examples include manholes affected by surface water runoff, holes in the ground smoking over services or sewer mains, and cracks in the street pavement that are smoking.

#### GUIDELINE

✦ Dye testing for SSES investigations shall be performed by experienced personnel trained in the proper safety measures for performing the testing including, but not limited to, confined space entry into storm drain and sanitary sewer manholes, measures for controlling water head buildup behind plugs, and traffic control measures. A fluorescent dye having a distinct color readily detectible by eye shall be used for dye testing. The dye shall be safe to handle, visible in low concentrations, miscible in water, biodegradable and inert to solids and debris in the sewer. Procedures for dye testing shall be as follows:

##### **Determining Conditions Caused by Storm Drain**

1. Plug both ends of the storm drain section to be tested with sand bags or sewer plugs and block all overflow and bypass points in the storm drain section. Bypass flow around the section under test if necessary.
2. Fill the storm drain section and stormwater inlets or catch basins to just below the grate with water. Add dye to the water.
3. Monitor the next downstream manhole in the sanitary sewer system for evidence of dyed water.
4. Measure the flow in the sanitary sewer manhole before and during dye testing. As an alternative, measure flow simultaneously at both the upstream and downstream sanitary manholes during the test.
5. Record the location of storm drain and sanitary sewer lines being tested; the time and duration of

the tests; the manholes where the flows are monitored; the observed presence, concentration and travel time of the dyed water to the flow monitoring manholes; and the soil characteristics.

**Determining Conditions Caused by Streams or Ditch Sections**

1. Plug or dam stream sections, ditch sections or ponded areas to be tested and fill to desired level with dyed water. Bypass flow around the section under test if necessary.
2. Follow steps 3 through 5 above.

**Identifying Sources on Private Property**

1. Notify property owners and receive permission for testing in advance of testing.
2. Insert dyed water into suspected inflow source and monitor closest downstream sanitary sewer manhole for evidence of dyed water.
3. Record the date of the test; address and type of the inflow source; duration of the test; the manholes where the flows are monitored; and the observed presence, concentration and travel time of the dyed water to the flow monitoring manholes.

**Identifying Structurally Damaged Manholes**

1. Flood the area around suspected manholes with dyed water.
2. Monitor manhole frame, chimney, cone and manhole walls for entry of dyed water.
3. Record the date of the test; manhole number; duration of the test; and the observed presence, concentration and travel time of the dyed water into the manhole.

**Verifying Sources Found by Other Testing Means**

1. Notify property owners and receive permission for testing in advance of testing if performed on private property.
2. Flood the area where visual survey or smoke testing study revealed potential I/I source. It may be necessary to restrict runoff from the area with sand bags to allow the area to become saturated.
3. Monitor the next downstream manhole in the sanitary sewer system for evidence of dyed water.
4. Measure the flow in the sanitary sewer manhole before and during dye testing. As an alternative, measure flow simultaneously at both the upstream and downstream sanitary manholes during the test.
5. Record the location of sources being tested, including address if on private property; the time and duration of the tests; the manholes where the flows are monitored; the observed presence, concentration and travel time of the dyed water to the flow monitoring manholes; and the soil characteristics.

A field log shall be filled out for all dye tests that are performed, regardless of whether a positive transference to the sanitary sewer is observed. A sketch of each testing setup shall be prepared showing testing location, manholes checked, dye transference information, and flooding time. The sketch shall also include the date and time of the test and the names of personnel. A photograph of each testing setup shall be taken and numbered. Photographs of the testing setup shall be referenced on the setup sketch. The appropriate agencies shall be notified of impending dye testing prior to test commencement.

**POTENTIAL LOCAL AGENCY IMPACTS**

- ⊕ Obtaining required permits for handling and disposal of test water volumes.
- ⊕ Obtaining and appropriately disposing of test water volumes.
- ⊕ Cost for additional staff workload, or contract with outside vendor.

**POTENTIAL KING COUNTY IMPACTS**

- ⊕ Obtaining required permits for handling and disposal of test water volumes.
- ⊕ Obtaining and appropriately disposing of test water volumes.
- ⊕ Cost for additional staff workload, or contract with outside vendor.

**POTENTIAL PRIVATE PROPERTY/RATEPAYER IMPACTS**

- ⊕ Property owners need to provide permission to perform testing on private property.
- ⊕ Some disturbance to yards/landscaping could occur during testing.

**I/I CONTROL GUIDELINE TITLE: Modeling and Engineering Analysis**

**GUIDELINE NO. PS-7**

**I/I CONTROL MEASURE ISSUE:**

Following the completion of the basin modeling performed during the Regional I/I Control Program, the modeling basins should be reevaluated with updated flow and system network information to provide an ongoing tool for monitoring the integrity of the sewer system as it both ages and expands. Hydraulic models can also be used to evaluate system response to potential high-flow sources such as high-water-use industries, adjoining jurisdictions, or large developments.

**GUIDELINE**

- ⊕ Basin modeling shall be conducted to assess system loading and capacity for ongoing and future sewer planning efforts. A dynamic software modeling program should be used that can be used to calibrate measured flow data with rainfall measured during the corresponding storm. The maximum model basin size shall be equivalent to the basins modeled by King County. Consideration should be given to selecting software that will provide output compatible with the King County model. Flow data shall be obtained by the Local Agency using the same methodology developed in the Regional I/I Control Program, including measurement of wet-weather/storm conditions and concurrent rainfall data. The flow monitoring preferably will coincide with the basins delineated for the King County I/I Control Program.
- ⊕ Development of a reliable, well-calibrated model requires good as-built plans and maps, and long-term flow monitoring data. The agency shall maintain an as-built record for new and modified piping.

**POTENTIAL LOCAL AGENCY IMPACTS**

- ⊕ Competency of staff in computer modeling and interpretation, or outsourcing to a consultant on a periodic basis.
- ⊕ Proactive planning and logistics for maintaining an as-built database.
- ⊕ Purchase of license for a sewer software model, or cost to develop alternative model.
- ⊕ Cost for training and operation of model by agency staff.
- ⊕ Expense for flow monitoring equipment and staff, whether purchased or leased/rented on a periodic basis.

**POTENTIAL KING COUNTY IMPACTS**

- ⊕ No impact, since King County now performs modeling analysis on a regular basis.

**POTENTIAL PRIVATE PROPERTY/RATEPAYER IMPACTS**

- ⊕ No impact.

**I/I CONTROL STANDARD TITLE: Connections to Existing System**

**STANDARD NO. PUB-1**

**I/I CONTROL MEASURE ISSUE:**

When new connections are made to the existing system, I/I potential exists from three general locations: 1) the connection itself leaks, 2) the system being added has leaks, and/or 3) the system being added has illegal connections that are inflow sources.

**STANDARD**

+ Connections to the existing system will only be allowed at manholes, to a main via an existing tee or a tap, or to the end of an existing pipe that meets all applicable I/I Standards.

+ Where a new manhole is being installed in an existing system, the I/I Standards for new manholes shall apply.

**Testing and inspection:**

+ The new conveyance system to be connected shall be inspected to confirm that no illicit connections contributing inflow have been added.

+ At manhole locations, the connection at the existing manhole shall be visually inspected for water tightness after the pipe has been completely backfilled and groundwater has returned to its natural elevation. The new line shall not be put into service until the connection has been inspected and approved.

**POTENTIAL LOCAL AGENCY IMPACTS**

+ Inspection requirements to confirm work performed correctly.

**POTENTIAL KING COUNTY IMPACTS**

+ No impact. King County already providing full-time inspection for construction and testing of new pipelines.

**POTENTIAL PRIVATE PROPERTY / RATEPAYER IMPACTS**

+ No impact.

**I/I CONTROL STANDARD TITLE: Sewers on Steep Slopes**

**STANDARD NO. PUB-2**

**I/I CONTROL MEASURE ISSUE:**

Pipe that is installed on steep slopes is more susceptible to movement, breakage, and slipped joints, which may allow I/I into the system. Special measures to anchor pipes installed on steep slopes may be required depending on the stability of the existing soils, local groundwater conditions, and the quality of the bedding and backfill construction during pipe installation.

**STANDARD**

⊕ Sewer mains on steep slopes shall be designed by a Professional Engineer to ensure the integrity of the system to prevent leakage and minimize I/I.

**POTENTIAL LOCAL AGENCY IMPACTS**

- ⊕ Agencies will need to verify that a Professional Engineer has addressed pipe anchoring requirements on steep slopes.
- ⊕ Pipe anchors can cost as much as \$1,000 each; however anchors are typically a requirement on steep slope pipeline installations.
- ⊕ Inspectors will need to verify that anchors are installed as designed.

**POTENTIAL KING COUNTY IMPACTS**

- ⊕ The County will need to verify that a Professional Engineer has addressed pipe anchoring requirements on steep slopes.
- ⊕ Pipe anchors can cost as much as \$1,000 each; however anchors are typically a requirement on steep slope pipeline installations.
- ⊕ Inspectors will need to verify that anchors are installed as designed.

**POTENTIAL PRIVATE PROPERTY/RATEPAYER IMPACTS**

⊕ No impact.

## I/I CONTROL STANDARD TITLE: Manhole Location and Covers

### STANDARD NO. PUB-3

#### I/I CONTROL MEASURE ISSUE:

Placement of manholes is important for two reasons. The potential for I/I will decrease by not placing it in a location subject to surface water flows or ponding. Proper location can improve an agency's ability to inspect and maintain the system, thus reducing I/I. When manholes must be placed in areas subject to surface water flows, inflow can be prevented by providing a watertight frame and cover system.

#### STANDARD

- ⊕ Manholes shall not be installed in areas subject to surface inundation such as pavement depressions and gutters. If this cannot be avoided, then the entire manhole, including cover, shall be designed as a watertight system. Buoyancy of the watertight manhole shall be accounted for in the design. For manholes placed in lakes or ponds a special watertight manhole, including access system, shall be designed to prevent leakage and to insure maintainability.
- ⊕ For manholes located in paved roadways, parking lots, or other areas that become subject to channelized stormwater flow due to re-grading, the manhole shall be retrofit with a watertight frame and cover system to prevent inflow.
- ⊕ Watertight frame and covers shall consist of a solid, gasketed cover or an approved manhole cover insert that stops the inflow of surface water into the manhole. Manhole cover inserts may be installed beneath a standard cover. Manhole cover inserts shall be in conformance with Standard Detail MH-3.

#### POTENTIAL LOCAL AGENCY IMPACTS

- ⊕ Added cost for watertight design in areas that may not now be required to be watertight.
- ⊕ Sewer system plan review would need to include an assessment of locations where manhole cover inserts are required.
- ⊕ Field inspection to ensure watertight manhole covers are installed where specified would be required.

#### POTENTIAL KING COUNTY IMPACTS

- ⊕ Added cost for watertight design in areas that may not now be required to be watertight.
- ⊕ Sewer system plan review would need to include an assessment of locations where manhole cover inserts are required.
- ⊕ Field inspection to ensure watertight manhole covers are installed where specified would be required.

#### POTENTIAL PRIVATE PROPERTY/RATEPAYER IMPACTS

- ⊕ Potentially higher ratepayer cost for watertight design.

**I/I CONTROL STANDARD TITLE: Manhole Size**

**STANDARD NO. PUB-4**

**I/I CONTROL MEASURE ISSUE:**

Providing a watertight seal at pipe penetrations is difficult when new or existing manholes are too small to accommodate all penetrations for incoming and outgoing pipes. Provisions to provide a minimum distance between manhole knockouts and minimum manhole sizes based on pipe size insure a watertight pipe connection can be made and help prevent structural failure of the manhole.

**STANDARD**

⊕ New manholes shall be sized so that the minimum distance between knockouts is in accordance with the requirements of the WSDOT/APWA Standard Specifications and the manhole manufacturers standards. A connection detail stamped and signed by a Professional Civil Engineer and approved by the manhole manufacturer shall be provided where the minimum distance between openings cannot be maintained.

**POTENTIAL LOCAL AGENCY IMPACTS**

- ⊕ Review of manhole shop drawings are required to insure that the minimum sizing and spacing requirements are being met, or that a connection detail prepared by a Professional Engineer is being provided.
- ⊕ Manhole construction costs may increase moderately in those agencies that allow contractors to make connections to existing manholes or size new manholes without requiring the specified minimum sizes or distance between knockouts and adjacent pipe connections.
- ⊕ Inspection of manhole construction is required to insure that the pipe locations and connections are as detailed and not field modified.

**POTENTIAL KING COUNTY IMPACTS**

- ⊕ Review of manhole shop drawings is required to insure that the minimum sizing and spacing requirements are being met, or that a connection detail prepared by a Professional Engineer is being provided.
- ⊕ Inspection of manhole construction is required to insure that the pipe locations and connections are as detailed and not field modified.

**POTENTIAL PRIVATE PROPERTY/RATEPAYER IMPACTS**

- ⊕ Potentially higher ratepayer costs in those agencies that do not require minimum distances between knockouts.

**I/I CONTROL STANDARD TITLE: Manhole Joints**

**STANDARD NO. PUB-5**

**I/I CONTROL MEASURE ISSUE:**

Joints in manholes present potential sources of I/I from the precast concrete manhole segments to adjustments rings and pipe penetrations.

**STANDARD**

- ⊕ All manholes shall be completely watertight from the top of the casting down.
- ⊕ Manholes materials and construction shall be in accordance with WSDOT/APWA Standard Specifications except as modified by this standard and Standard Details MH-1 and MH-2.
- ⊕ Precast concrete manhole sections shall be joined with either rubber or flexible plastic gaskets.
- ⊕ All lifting holes shall be completely filled with non-shrink grout.
- ⊕ Typical pipe penetrations through precast concrete sections shall be either factory knockouts or core drilled (not line drilled or rough broken) cutouts. Pipe shall enter the manhole through a rubber gasketed entry coupling specifically design for a flexible, watertight connection either cast into the manhole section or grouted in place with non-shrink grout.
- ⊕ Where a new manhole is being constructed as a “saddle manhole”, which is built around an existing sewer main, the manhole shall be designed by a Professional Civil Engineer. The saddle manhole shall be of sufficient diameter to provide a watertight connection between the manhole and the wall of the existing pipe.

**POTENTIAL LOCAL AGENCY IMPACTS**

- ⊕ No major impact because most agencies currently meet this standard.

**POTENTIAL KING COUNTY IMPACTS**

- ⊕ No impact because King County currently meets this standard.

**POTENTIAL PRIVATE PROPERTY/RATEPAYER IMPACTS**

- ⊕ No impacts.

**I/I CONTROL STANDARD TITLE: Side Sewer Connection Location and Taps**

**STANDARD NO. PUB-6**

**I/I CONTROL MEASURE ISSUE:**

The location of a side sewer connection to a mainline in an area with difficult access or in such a manner as to induce unnecessary stress on the system can make them more prone to damage and less apt to be maintained, thus resulting in I/I. Good construction techniques and proper selection of materials for side sewer taps can reduce I/I by protecting the mainline from damage by providing a watertight seal.

**STANDARD**

- + No side sewers shall be connected to a main located in a lake or similar body of water except under special circumstances.
- + If a side sewer must be connected at a manhole, then it shall penetrate the manhole wall through a watertight rubber gasketed factory manhole adapter specially designed for the side sewer material type. A mortared connection at a manhole will not be permitted unless the structure is constructed as a saddle manhole.
- + All connections to existing mains shall be made at an existing tee fitting or by core drilling a hole in the existing sewer main and installing an approved gasketed factory sewer saddle or cutting in a gasketed factory tee. The Local Agency may consider other connection alternatives if the method can be demonstrated to provide a watertight connection. Line drilling or rough breakouts shall not be used.
- + For a tapped connection to the mainline, the hole shall be as small as possible to accommodate the outside diameter of the side sewer pipe with adequate space for minor angle alignment adjustments of the side sewer. The connection shall be made with a factory saddle specifically designed for side sewer connections and fabricated of corrosion resistant materials and mechanically attached to the pipe to withstand the anticipated loads. The saddle shall provide a rubber gasketed joint between the sewer main and the saddle.
- + Factory tees shall be appropriate for the soil conditions encountered in the connection location and shall have rubber gasketed joints. Material selection shall take into account the soil corrosivity, compatibility of materials with the existing pipe, strength requirements, and bedding/backfill conditions. The tee shall be connected to the existing sewer main pipe by short sections of plain end pipe and an approved stainless steel repair clamp. The short sections of pipe shall match the sewer main pipe material and shall meet or exceed the strength of the existing system. Stainless steel repair clamps shall be gasketed, with a minimum length of two pipe diameters, and assembled with all stainless steel bolts and nuts.

**POTENTIAL LOCAL AGENCY IMPACTS**

- + Inspection requirements to confirm compliance with standards or do tap itself.
- + Moderate cost of using saddles.
- + High cost of using cut in tees and dealing with active sewer line.

**POTENTIAL KING COUNTY IMPACTS**

- + No impact, since King County does not normally allow side sewer connections to its conveyance system.

**POTENTIAL PRIVATE PROPERTY/RATEPAYER IMPACTS**

- + Added cost for doing the tee when the side sewer is too large for a tap.
- + Added cost to core drill the pipe.

**I/I CONTROL STANDARD TITLE: Sewer System Design**

**STANDARD NO. PUB-7**

**I/I CONTROL MEASURE ISSUE:**

Structural failure of pipe and manholes can lead to infiltration of groundwater. The following are key factors contributing to the impairment of a sewer systems’ structural abilities, resulting in I/I:

- Sewer mains, manholes, laterals and side sewers that are not properly supported are subject to vertical displacements over time, causing joints to open and pipeline trenches to settle, producing cracks or breaks in sections of the pipe.
- Materials must be appropriate for design conditions and the ground conditions present. Pipeline failures often occur due to the misuse of materials.
- Structural failure of sewer pipes allows groundwater to enter the system at the point of connection to manholes. Deep cuts and poor ground conditions often result in a larger than necessary excavation, leading to unequal settlement if uniform support is not provided for the pipe and manhole. Inadequate support often causes failure of the pipe in shear at the manhole and provides a point of entry for groundwater.

Recognizing past situations that have allowed extraneous flows to enter the system and requiring sound and appropriate design measures to prevent these deficiencies on future projects can greatly reduce future I/I.

**STANDARD**

⊕ Sewer system design shall be performed by a civil engineer licensed in the State of Washington. The designer shall verify that sound and appropriate standards and measures have been employed in the design of new sewer systems. This shall include the choice of sewer materials for the design conditions, pipe bedding and backfill requirements, and the evaluation for pipe casing requirements.

**POTENTIAL LOCAL AGENCY IMPACTS**

⊕ Agencies will need to verify that the designer has adequately addressed elements of the sewer design that relate to the structural integrity of the system.

**POTENTIAL KING COUNTY IMPACTS**

⊕ King County will need to verify that the designer has adequately addressed elements of the sewer design that relate to the structural integrity of the system.

**POTENTIAL PRIVATE PROPERTY/RATEPAYER IMPACTS**

⊕ No impacts.

**I/I CONTROL STANDARD TITLE: Abandonment Requirements**

**STANDARD NO. PUB-8**

**I/I CONTROL MEASURE ISSUE:**

Abandoned sewer pipes and manholes that are not completely isolated from the remaining system pose potential sources for I/I. Abandoned sewer mains are defined as any section of pipe extended beyond a manhole with no services attached and no plan for future extension or service connection(s). Abandoned side sewers fall into two categories. If no future connection is anticipated, then the entire side sewer from the main is considered abandoned. If a future connection is anticipated, then the side sewer shall be considered abandoned at the property line.

**STANDARD**

- ⊕ **Manholes:** Manholes shall not be abandoned if they are on the end of an active sewer main. If the manhole is part of an abandoned pipe system, then it shall be completely filled and all pipes physically connected to the manhole shall be plugged.
- ⊕ **Sewer Main Pipe:** Abandoned sewer main pipes shall be plugged with a minimum of length of 3 pipe diameters with a non-shrink grout or other impermeable material at the manhole. The pipe shall be prepared to provide a watertight bond between the plug material and existing pipe.
- ⊕ **Sewer Main Abandonment Inspection:** The plug shall be visually inspected for any leaks during the wet season while under warranty.
- ⊕ **Side Sewers:** Abandoned side sewer pipe shall be capped with a watertight plug for future use or plugged with a minimum of length of 3 pipe diameters with a non-shrink grout or other impermeable material. The pipe shall be prepared to provide a watertight bond between the plug material and existing pipe.
- ⊕ **Side Sewer Abandonment Inspection:** Plugged side sewers shall be CCTV inspected for leakage at the sewer main connection during the wet season while under warranty.

**POTENTIAL LOCAL AGENCY IMPACTS**

- ⊕ Inspection requirements to confirm that the work was done correctly.

**POTENTIAL KING COUNTY IMPACTS**

- ⊕ No impact, since pipe abandonment is not anticipated in the King County system.

**POTENTIAL PRIVATE PROPERTY/RATEPAYER IMPACTS**

- ⊕ Potentially higher ratepayer costs for increased inspection costs.

## **I/I CONTROL STANDARD TITLE: Pipe Rehabilitation Methods**

### **GUIDELINE NO. PUB-9**

#### **I/I CONTROL MEASURE ISSUE:**

Once the decision has been made to rehabilitate a sewer to control I/I, several alternatives may be used to replace the existing sewer. These include trenchless rehabilitation techniques such as cure-in-place lining, pipe bursting and conventional dig and replace. An evaluation should be made to determine suitability (technical and cost effectiveness) of trenchless methods versus conventional dig and replacement of the sewer. The technical evaluation should assess specific issues such as the sewer location, alignment, condition of the pipe being replaced, and future service requirements for the sewer. If the rehabilitation technique will reduce the cross sectional flow area of the pipe the technical evaluation should consider loss in hydraulic capacity of the line in accordance with the I/I Design Capacity for Pipeline Standard. The alternative pipe rehabilitation methods that should be considered include:

Pipe bursting is a trenchless pipeline rehabilitation method that can be used to replace sewer pipes. Reduction of excess flow is achieved by eliminating sources of infiltration in the piping being replaced. It is possible to increase the size of the pipe; however, site specific constraints may limit the ability to increase the size. Using pipe bursting to replace a pipe may be restricted depending upon adjacent utilities, proximity to a road surface, the type of existing pipe being replaced, and soil conditions. There are a number of variations on pipe bursting such as pneumatic, hydraulic expansion, and static pull systems. All of these displace the old pipe into the adjacent ground and pull a new pipe in to replace the old pipe. There are also related processes such as pipe reaming, which is a variation of horizontal directional drilling, where pieces of the old pipe are removed rather than pushing them into the adjacent soil. Pipe bursting may be used for mainline, lateral, and side sewer repair. The most common pipe material used is HDPE but other types of pipe material such as cast iron, MDPE, and ABS can be used for the replacement pipe.

Cure-in-place pipe (CIPP) liner is a trenchless pipeline rehabilitation method that can be used to repair existing sewer pipes. Reduction of excess flow is achieved by eliminating sources of infiltration in the piping being rehabilitated. CIPP liner involves inverting an epoxy-resin-impregnated flexible tube into an existing line using hydrostatic head. The resin is then cured using heat to produce a pipe inside the existing pipe. The outside diameter of the replacement pipe is smaller than the existing pipe to allow the system to be installed. Capacity in the pipeline will be reduced because of the reduction in pipe size.

Slip lining is a trenchless pipeline rehabilitation method that can be used to replace sewer pipes. Reduction of excess flow is achieved by eliminating sources of infiltration in the pipe being replaced. Slip lining involves pushing or pulling a replacement pipe into an existing pipe. The outside diameter of the replacement pipe is smaller than the inside diameter of the existing pipe to allow the replacement pipe to be installed. Capacity in the pipeline will be reduced because of the reduction in pipe size. A variety of pipe materials may be used for slip lining including HDPE, ductile iron, PVC, concrete and fiberglass. The annular space should be grouted unless there are project specific reasons to do otherwise.

Fold and form lining is a trenchless pipeline rehabilitation method that can be used to repair existing sewer pipes. Reduction of excess flow is achieved by eliminating sources of infiltration in the piping being replaced. The fold-and-form process involves inserting a heated PVC or HDPE thermoplastic liner, folded or deformed into a U-shape, into an existing sewer and re-rounding the liner using heat and pressure to produce a pipe inside the existing pipe. The outside diameter of the replacement pipe is smaller than the existing pipe to allow the system to be installed. Capacity in the pipeline will be reduced because of the reduction in pipe size.

**GUIDELINE**

+ Construction standards for pipe bursting, cure-in-place lining, slip-lining and folded and formed liners shall be as follows:

+ Pipe Bursting:

- Pipe bursting shall meet the requirements of the King County Regional Inflow and Infiltration Control Program Guide Specifications.

+ Cure-in-Place Lining:

- Cure-in-place-lining shall meet the requirements of the King County Regional Inflow and Infiltration Control Program Guide Specifications.
- Service connections to the new lined pipe shall be made water tight by grouting the area where the service connection enters the lined pipe or by installing a service connection rehabilitation liner in conformance with the King County Regional Inflow and Infiltration Control Program Guide Specifications.

+ Slip Lining:

- Slip lining shall conform to ASTM F585-94 – “Standard Practice for Insertion of Flexible Polyethylene Pipe Into Existing Sewers”.
- The type of replacement pipe used shall meet or exceed the requirements for sewer pipe materials in I/I Pipe Materials Standard and shall be suitable for the slip lining process being used.
- New pipe connections to manholes shall provide a water tight connection suitable for the type of replacement pipe being used and in accordance with the I/I Connections to Existing System Standard. Acceptable manhole connections may include commercially available manhole connection boots or the pipe grouted into the manhole pipe penetration with a seep ring on the pipe.
- Lateral connections to the new pipe shall also be made using commercially available fittings suitable for the type of replacement pipe. For HDPE pipe, lateral wyes or tees shall be made using manufacturer provided fusion welded fittings or other Local Agency approved fittings specifically manufactured for HDPE pipe.
- The annular space shall be grouted unless there are project specific reasons to do otherwise. Issues to be considered relative to the annular space grouting include grouting pressures and pipe restraint to prevent floatation.

+ Fold and Form:

- Fold and form-lining shall meet the requirements of the King County Regional Inflow and Infiltration Control Program Guide Specifications.

**POTENTIAL LOCAL AGENCY IMPACTS**

+ Inspection requirements to confirm that the trenchless rehabilitation is done correctly.

**POTENTIAL KING COUNTY IMPACTS**

+ Inspection requirements to confirm that the trenchless rehabilitation is done correctly.

**POTENTIAL PRIVATE PROPERTY/RATEPAYER IMPACTS**

+ No impact.

**I/I CONTROL STANDARD TITLE: Manhole Rehabilitation**

**GUIDELINE NO. PUB-10**

**I/I CONTROL MEASURE ISSUE:**

Manhole rehabilitation can be used to eliminate sources of both infiltration and inflow directly into the structure where the rehabilitation is determined to be more cost effective than replacement of the manhole. There are a variety of rehabilitation techniques, including manhole grouting, cementitious spray-on lining, epoxy linings, manhole inserts, and cure-in-place liners. Many of the methods provide benefits other than just I/I reduction such as protection from internal corrosion due to hydrogen sulfide. Manhole rehabilitation for I/I reduction may also include replacement of manhole rings or replacement of the ring and cover.

**GUIDELINE**

⊕ When a manhole is rehabilitated for I/I reduction, consideration shall be given to factors that contributed to the current condition and whether the selected rehabilitation will prevent the potential recurrence of I/I. Rehabilitation techniques include spray on coatings, cure-in-place linings, chemical grouting, or a rigid liner installed within the existing manhole. Coatings, linings and chemical grouting for manhole rehabilitation shall meet the requirements of the King County Regional Inflow and Infiltration Control Program Guide Specifications.

**POTENTIAL LOCAL AGENCY IMPACTS**

- ⊕ Inspection requirements to confirm that the manhole preparation and rehabilitation is done correctly.
- ⊕ Potential surface disruptions resulting from construction of the rehabilitation.
- ⊕ Costs to test the completed manhole rehabilitation.

**POTENTIAL KING COUNTY IMPACTS**

- ⊕ Costs to test the completed manhole rehabilitation.
- ⊕ Inspection requirements to confirm that the manhole preparation and rehabilitation is done correctly.

**POTENTIAL PRIVATE PROPERTY/RATEPAYER IMPACTS**

- ⊕ Potential inconveniences resulting from rehabilitation construction activities.

**I/I CONTROL STANDARD TITLE: Spot Repairs**

**GUIDELINE NO. PUB-11**

**I/I CONTROL MEASURE ISSUE:**

Pipeline spot repairs are repairs to specific deficiencies in a pipeline, such as a specific leaking pipe joint. These repairs can be a cost effective way to eliminate I/I in sections of a pipeline that are sound except for a few point locations. Only those specific deficiencies in the pipeline are repaired. In general, in pipeline sections that require three or more spot repairs, it is often more cost effective to consider the entire manhole-to-manhole run of pipe for rehabilitation or replacement.

**GUIDELINE**

- ⊕ Spot repairs can be accomplished by several different methods from trenchless systems like short CIPP liners, to injecting epoxy resins or chemical grout into leaking pipe joints, to dig and repair with structural grouting sleeves or short sections of pipe replacement. The repair method shall address whether the defect is structural or limited to intact leaky joint. Spot repairs may be needed to properly prepare the line for some of the manhole-to-manhole rehabilitation/replacement options.
- ⊕ For a dig and replace spot repair, the section of the sewer main shall be removed to the nearest joint and replaced with new pipe. The new section of pipe shall be installed with repair couplings meeting the Local Agency’s approval but in any case shall provide a water tight repair.
- ⊕ Trenchless spot repairs shall meet the I/I standard for the particular rehabilitation method used.
- ⊕ If SSES reveals there are 3 or more defects that require repair on a manhole to manhole run of sewer main, it is recommended that the entire run of sewer be evaluated for rehabilitation or replacement.

**POTENTIAL LOCAL AGENCY IMPACTS**

- ⊕ The costs associated with testing and inspecting the spot repair.
- ⊕ Surface disruptions from construction activities may inconvenience the public.

**POTENTIAL KING COUNTY IMPACTS**

- ⊕ The costs associated with testing and inspecting the spot repair.

**POTENTIAL PRIVATE PROPERTY/RATEPAYER IMPACTS**

- ⊕ No impact.

**I/I CONTROL STANDARD TITLE: Manhole Leveling Rings**

**STANDARD NO. PUB-12**

**I/I CONTROL MEASURE ISSUE:**

The manhole grade-adjustment rings for the frame and cover can be a source of infiltration.

**STANDARD**

- ⊕ Materials for grade adjustment of manholes shall consist of precast concrete rings specifically designed for the diameter of the manhole entrance and anticipated loads. Other materials for the rings may be considered provided they provide adequate support, are impermeable, provide a watertight seal, and have a serviceable life expectancy of 50 years or over.
- ⊕ Adjustments of the frame and cover shall be made with precast concrete rings and joined with mortar meeting the requirements of Section 9-04.3 of the WSDOT/APWA Standard Specifications or flexible plastic/mastic gaskets. If leveling rings are used that are manufactured from materials other than concrete, the installation of the rings and adjustment to grade shall be in accordance with the manufacturer's recommendations.
- ⊕ If mortar joints are used, consideration shall be given to infiltration leakage that could occur through the rings. This may include wrapping the full height of the exterior of the manhole rings with a membrane sealing system.
- ⊕ Testing and inspection: If mortar joints are used, they shall be inspected before backfilling.

**POTENTIAL LOCAL AGENCY IMPACTS**

- ⊕ Additional cost of inspection and testing of the manhole.

**POTENTIAL KING COUNTY IMPACTS**

- ⊕ Additional cost of inspection and testing of the manhole.

**POTENTIAL PRIVATE PROPERTY/RATEPAYER IMPACTS**

- ⊕ No impacts.

**I/I CONTROL STANDARD TITLE: Manhole Lids/Inserts**

**STANDARD NO. PUB-13**

**I/I CONTROL MEASURE ISSUE:**

Older style manhole covers may contain numerous pick holes that allow inflow into the collection system during storm events. Old and new manhole covers are both susceptible to inflow through or around the cover if water ponds over the cover. Eliminating this source of inflow will reduce excess flow from entering the system. Replacing the cover with a new cover will reduce or eliminate this source of inflow.

**STANDARD**

- ⊕ Manhole covers that have been identified through an SSES as being susceptible to inflow may be replaced with a gasketed solid cover or just the ring or cover may be replaced if it is determined to be the source of the problem.
- ⊕ In lieu of replacing the cover a manhole insert may be installed under the existing cover to eliminate or reduce the volume of inflow that enters the sewer. Manhole inserts are metal or plastic pans installed just under the manhole cover and are supported by the manhole ring. All materials used in the manufacture of manhole inserts shall be plastic or stainless steel in accordance with Standard Detail MH-3.

**POTENTIAL LOCAL AGENCY IMPACTS**

- ⊕ Replacement of the entire manhole ring and cover assembly will be costly.
- ⊕ Installation will be disruptive to traffic if the manhole is located in a street.
- ⊕ Solid, gasketed covers cost approximately \$100 more than conventional covers with pick holes.

**POTENTIAL KING COUNTY IMPACTS**

- ⊕ Replacement of the entire manhole ring and cover assembly will be costly.
- ⊕ Installation will be disruptive to traffic if the manhole is located in a street.
- ⊕ Solid, gasketed covers cost approximately \$100 more than conventional covers with pick holes.

**POTENTIAL PRIVATE PROPERTY/RATEPAYER IMPACTS**

- ⊕ Possibly traffic inconveniences during the ring and cover replacement.

**I/I CONTROL STANDARD TITLE: Root Intrusion**

**STANDARD NO. PUB-14**

**I/I CONTROL MEASURE ISSUE:**

Pipelines that have roots protruding in the pipe have a breach in the piping system at a joint and/or a break in the pipe. This breach is a potential source for infiltration. Cutting of the roots inside the pipe and treatment with a root-inhibiting chemical will not remove infiltration. Root intrusion can cause operational problems by plugging the sewer and will likely need to be corrected to address this problem.

**STANDARD**

- ⊕ When roots are found in sewer piping and manholes, the point of entry shall be located by CCTV. If infiltration occurs at the point of root intrusion it shall be evaluated for removal during the wet season when surrounding soils are fully saturated. Correction of infiltration caused by roots can be accomplished by performing a spot repair by either a conventional dig and repair or using a trenchless repair method.
- ⊕ If the segment of sewer indicates potential for additional root intrusion, consideration shall be given to replacing the sewer using either dig and replace or trenchless methods.

**POTENTIAL LOCAL AGENCY IMPACTS**

- ⊕ Added cost to test and repair the entire section of main from manhole-to-manhole.

**POTENTIAL KING COUNTY IMPACTS**

- ⊕ No impact, since root intrusion is not usually a problem on King County interceptor sewers.

**POTENTIAL PRIVATE PROPERTY/RATEPAYER IMPACTS**

- ⊕ Added cost due to increased cost to maintain system.
- ⊕ Cost savings or reduction in rate increase due to less I&I treatment costs.

**I/I CONTROL STANDARD TITLE: Pipeline Leak Testing**

**STANDARD NO. PUB-15**

**I/I CONTROL MEASURE ISSUE:**

Several aspects of sewer main pipe installation, if not properly designed and constructed, may result in infiltration entering the finished pipeline. Leakage testing of the assembled sewer pipeline immediately following construction is one of the final opportunities for verification that the pipeline meets acceptable I/I criteria prior to being placed into service.

Leakage testing of newly installed replacement sewer mains may not be feasible because active side sewers are being installed on the new line as construction progresses. For these cases, CCTV inspection of the completed line will be required in lieu of a leakage test.

**STANDARD**

⊕ Acceptance criteria for substantial completion following construction of new and rehabilitated pipelines shall include testing requirements to ensure that the sewer pipelines and connections to the sewer pipelines, as constructed, meet specified leakage limitations. Where new sewer mains can be isolated from active flow, the pipeline shall be tested by either a water test or a low pressure air test. For those cases where flow cannot be routed around the new main, the pipeline shall be CCTV inspected for leakage.

⊕ The water test shall be an infiltration test if the sewer main is installed below the groundwater level. The water test shall be an exfiltration test if the sewer main is installed above the groundwater level. Testing shall be in accordance with the WSDOT/APWA Standard Specifications.

⊕ Low pressure air testing shall conform to the requirements of the WSDOT/APWA Standard Specifications.

⊕ Where wastewater flow cannot be routed around the new main as construction progresses, the pipeline shall be CCTV inspected for leakage. While under warranty, it is recommended that a visual inspection for leakage be performed during the wet season when surrounding soils are fully saturated.

**POTENTIAL LOCAL AGENCY IMPACTS**

⊕ Possible additional cost and additional staffing requirements for acceptance and inspection verification.

**POTENTIAL KING COUNTY IMPACTS**

⊕ Possible additional cost and additional staffing requirements for acceptance and inspection verification.

**POTENTIAL PRIVATE PROPERTY/RATEPAYER IMPACTS**

⊕ Potentially higher ratepayer costs for increased visual inspection/verification requirements.

**I/I CONTROL STANDARD TITLE: Manhole Leak Inspection**

**STANDARD NO. PUB-16**

**I/I CONTROL MEASURE ISSUE:**

Several aspects of sewer manhole installation, if not properly designed and constructed, may result in infiltration entering the finished sewer system. Leakage inspection of the assembled manhole during the first wet season following construction is the best opportunity for verification that the manhole meets acceptable I/I criteria prior to being placed into service.

A final visual inspection for manhole leakage to confirm that as-built conditions have not degraded due to material failures, bedding or backfill settlement, or other causes needs to be performed at the end of the warranty period.

**STANDARD**

⊕ Acceptance criteria following construction on new and rehabilitated manholes shall include a visual inspection to ensure that the manholes and connections to the manholes, as constructed, are watertight. Groundwater level shall be allowed to return to its normal elevation before performing the inspection. It is recommended that the visual inspection for manhole leakage be performed during the wet season when surrounding soils are fully saturated.

**POTENTIAL LOCAL AGENCY IMPACTS**

⊕ Possible additional cost and additional staffing requirements for visual inspections.

**POTENTIAL KING COUNTY IMPACTS**

⊕ Possible additional cost and additional staffing requirements for visual inspections.

**POTENTIAL PRIVATE PROPERTY/RATEPAYER IMPACTS**

⊕ Potentially higher ratepayer costs for increased inspection requirements.

**I/I CONTROL STANDARD TITLE: CCTV Inspection**

**STANDARD NO. PUB-17**

**I/I CONTROL MEASURE ISSUE:**

Television inspection of newly installed and rehabilitated sewers provides documentation of lateral connections, confirms pipe joints are properly pushed home, and identifies infiltration and internal defects.

**STANDARD**

⊕ A complete, televised inspection of sewer pipe shall be performed on newly installed and rehabilitated sewers. An audio-visual tape recording of the inspection, compatible with the Local Agency’s existing audio-visual format, shall be retained by the Local Agency. A complete television inspection of newly installed and rehabilitated sewer laterals shall be performed where the lateral cannot be pressure tested. The CCTV inspection of the lateral shall include all portions of the lateral installed or rehabilitated on the project. If camera access through a lateral test wye cannot be provided, the video camera equipment shall have a separate side-casting camera that allows inspection of the lateral. The television inspection shall be conducted following trench backfill and compaction, cleaning and testing. Groundwater level shall be allowed to return to its normal elevation before performing the inspection.

**POTENTIAL LOCAL AGENCY IMPACTS**

- ⊕ Additional camera equipment to inspect laterals may be required by agencies that perform their own CCTV inspection of new construction.
- ⊕ Additional inspection time to examine lateral construction may be required for those agencies performing their own CCTV inspection of new construction.
- ⊕ A slight increase in construction costs will result for agencies that currently do not require the contractor to perform the CCTV inspections of laterals.

**POTENTIAL KING COUNTY IMPACTS**

- ⊕ No impact since King County normally performs CCTV inspection of new and rehabilitated mains and does not normally allow lateral connections to their trunk sewers.

**POTENTIAL PRIVATE PROPERTY/RATEPAYER IMPACTS**

- ⊕ Television inspection of the lateral insures there are no internal defects, potentially reducing future private property owner maintenance requirements due to improper installation.
- ⊕ Potentially higher ratepayer costs for increased CCTV inspection requirements.

**I/I CONTROL STANDARD TITLE: Inspection of Pipe Installation and Backfill****STANDARD NO. PUB-18****I/I CONTROL MEASURE ISSUE:**

Inspection of pipe and bedding materials; foundation conditions; and pipe laying, bedding and backfill operations is necessary to ensure conformance with the required standards. A visual inspection of connections to the new main line should be performed to verify that no disallowed connections, such as from storm water collection sources, are being made to the system. Without adequate inspection, contractors may take construction shortcuts that result in a substandard pipeline installation.

**STANDARD**

- ⊕ The Local Agency shall perform the following inspection activities on pipeline installations:
  - Inspection of foundation conditions in areas of questionable soils to verify whether over-excavation is required.
  - Visual inspection of pipe materials and bedding and backfill materials for conformance with standards.
  - Measurement of compaction and density for conformance with bedding and backfill standards.
  - Visual inspection of pipe laying operations to ensure pipe has full, uniform support, pipe-jointing process is being properly performed, and compaction operations are not damaging the pipe.
  - Visual inspection of service connections to the mainline and manholes to verify no surface water collection sources are being connected to the sanitary sewer system.
- ⊕ A minimum of 10% of the pipe length should be inspected as noted above. Above and beyond the minimum inspection, the Local Agency shall make the determination on the required frequency of the inspection based on the qualifications and quality of the contractor performing the work.

**POTENTIAL LOCAL AGENCY IMPACTS**

- ⊕ Agency will need the inspection resources to adequately cover sewer construction work occurring within the agency.
- ⊕ The following Local Agency inspection items should be performed for all pipeline installations:
  - Inspection of foundation conditions in areas of questionable soils to verify whether over-excavation is required.
  - Visual inspection of pipe materials and bedding and backfill materials for conformance with standards.
  - Conformance with compaction and density standards for bedding and backfill.
  - Visual inspection of pipe laying operations to ensure pipe has full, uniform support, pipe jointing process is being properly performed and compaction operations are not damaging the pipe.
  - Visual inspection of service connections to the mainline and manholes to verify no surface water collection sources are being connected to the sanitary sewer system.
- ⊕ Administrative costs for on-site inspection will increase for those agencies that are not currently inspecting pipe installation and backfill operations.
- ⊕ Inspection of pipe installation and backfill operations insures installation according to the standards, resulting in a more long-lasting and dependable facility. In the long-term, proper inspection of critical pipeline installation operations can save future maintenance, rehabilitation and replacement costs.

**POTENTIAL KING COUNTY IMPACTS**

- ⊕ No impact. King County currently provides full time inspection on all construction projects.

**POTENTIAL PRIVATE PROPERTY/RATEPAYER IMPACTS**

⊕ Potential higher ratepayer costs in those agencies where inspection is not currently being performed.

**I/I CONTROL STANDARD TITLE: Product Specific Inspection**

**STANDARD NO. PUB-19**

**I/I CONTROL MEASURE ISSUE:**

Products used in sewer system construction for both new and rehabilitation improvements can fail and lead to I/I due to improper installation and/or the use of non-specified products being installed. Without inspection, there are no assurances the product installed is the one specified and was installed properly.

**STANDARD**

- ⊕ Product inspection is the visual verification of product test results and/or confirmation that an approved product is the one being installed, and the sequence of construction or application is appropriate. Verify the approved product is being installed in accordance with approved specifications. This includes pipe, fittings, bedding, and rehabilitation products. It is important to distinguish the difference between inspection and testing. Those products covered under the testing standard shall have those tests performed to verify compliance.
- ⊕ Pipe shall be inspected at the point of installation to verify that it has factory markings identifying the type and class of pipe. Unlabeled products will not be approved for installation.
- ⊕ Pipe fittings shall be inspected at the point of installation to confirm they meet the specifications.
- ⊕ Pipe bedding material shall be inspected at the time of installation to be appropriate for the type of pipe (flexible or rigid).
- ⊕ For rehabilitation products, the manufacturer’s recommended installation procedure shall be reviewed prior to installation. An installation list with references shall be provided documenting recent projects where the product has been installed. Contact references and document the installation and operational experiences with the product. Conduct any additional investigations determined necessary for approval of the product and installation. If through this review the product appears acceptable, the installation requirements shall be documented from the review process along with any testing requirements of the installation.

**POTENTIAL LOCAL AGENCY IMPACTS**

- ⊕ Added cost for increased inspection.
- ⊕ Additional qualification investigation for proposed rehabilitation products.

**POTENTIAL KING COUNTY IMPACTS**

- ⊕ No impact, since King County already doing full time inspection.

**POTENTIAL PRIVATE PROPERTY/RATEPAYER IMPACTS**

- ⊕ Potentially higher ratepayer costs in agencies where product specific inspection is currently not being performed.

## **I/I CONTROL GUIDELINE TITLE: Certification, Warranty and Qualifications**

### **GUIDELINE NO. PUB-20**

#### **I/I CONTROL MEASURE ISSUE:**

Some new construction and/or rehabilitation products or application systems may not have a proven track record of performance, yet offer attractive benefits or low costs which merit their use. A product specific certification can be used to protect the Local Agency's investment.

Every construction or rehabilitation project requires a period within which defects in construction or materials should be allowed to become evident before the contractor, supplier or manufacturer ceases to have responsibility for the project. A stipulated warranty length can be used to protect the Local Agency's investment. Conventional construction products and methods should be warranted for a period of at least one year. Unconventional or newer products and methods could be warranted for a longer period, from 2 to 5 years, as determined by the Local Agency's Engineer.

A formal procedure for qualifying a manufacturer or contractor can be used to protect the Local Agency's investment. Qualifications information to be supplied during bidding may include a summary of the firm's history, itemization of a number of recent, similar projects with descriptions, amounts, names and experience of specific firm representatives, and names/phone numbers of owner references.

It is vital that the certification, warranty and qualification requirements and procedures be fully described in the contract documents to be enforceable with the contractors and suppliers.

#### **GUIDELINE**

- ⊕ When a new construction and/or rehabilitation product or application system does not have a documented record of comparable prior successful installations, the supplier of the product or system shall be required to provide certification that the product or system will perform as specified.
- ⊕ The certification shall provide for the complete replacement of the product or system by the contractor if the product or system is found to be defective when installed or applied by a certified agent of the manufacturer.
- ⊕ Each new construction and/or rehabilitation project shall include a warranty period of at least one year. Longer periods may be stipulated as determined by the Local Agency based on the nature of the work.
- ⊕ Testing requirements at the end of the warranty period shall be consistent with those used to determine initial project acceptance.
- ⊕ The Local Agency may determine that specific qualifications for the manufacturer or contractor be included in the evaluation of bids received.

#### **POTENTIAL LOCAL AGENCY IMPACTS**

- ⊕ Staff or consultant Engineer will need to spend time to research and develop a certification period as well as a means for determining compliance.
- ⊕ Verification of certification requirements during the submittal process will be required.
- ⊕ Inspection during construction to monitor installation/application will increase staffing requirements.
- ⊕ Follow-up time by staff to monitor product or system performance may delay project completion and may increase staff requirements.
- ⊕ Potential for additional project cost by manufacturer or contractor.
- ⊕ Staff or consultant Engineer needs to determine appropriate qualification procedures.
- ⊕ Staff or consultant Engineer needs to determine appropriate length of warranty period.
- ⊕ Legal and engineering effort to establish acceptable pre-qualification requirements will be greater.
- ⊕ Time needed to determine qualification information during bid evaluation period will be longer.

- ⊕ There is potential for increased bid prices.
- ⊕ Additional engineering and legal costs during design and bid periods are likely to occur.

**POTENTIAL KING COUNTY IMPACTS**

- ⊕ Staff or consultant Engineer will need to spend time to research and develop a certification period as well as a means for determining compliance.
- ⊕ Verification of certification requirements during the submittal process will be required.
- ⊕ Inspection during construction to monitor installation/application will increase staffing requirements.
- ⊕ Follow-up time by staff to monitor product or system performance may delay project completion and may increase staff requirements.
- ⊕ Potential for additional project cost by manufacturer or contractor.
- ⊕ Staff or consultant Engineer needs to determine appropriate qualification procedures.
- ⊕ Staff or consultant Engineer needs to determine appropriate length of warranty period.
- ⊕ Legal and engineering effort to establish acceptable pre-qualification requirements will be greater.
- ⊕ Time needed to determine qualification information during bid evaluation period will be longer.
- ⊕ There is potential for increased bid prices.
- ⊕ Additional engineering and legal costs during design and bid periods are likely to occur.

**POTENTIAL PRIVATE PROPERTY/RATEPAYER IMPACTS**

- ⊕ Potentially higher ratepayer costs for certifications and longer warranty periods.

## I/I CONTROL GUIDELINE TITLE: Pipe Protection-Depth of Cover

### GUIDELINE NO. PRV-1

#### I/I CONTROL MEASURE ISSUE:

Shallow buried flexible pipe is susceptible to damage from heavy live loads and construction loads. Deeply buried flexible pipe is susceptible to damage from heavy soil loading. Pipe type, class, and the quality of the pipe bedding installation are especially important for flexible pipe buried less than 3 feet deep and greater than 15 feet deep beneath a general fill. Standard industry practice based on load testing, engineering analysis and field experience is to maintain a minimum cover over flexible pipe of 3 feet to avoid damage from heavy live loads and construction loads. Burial depths greater than 15 feet create soil loading conditions that exceed the capacity of flexible pipe unless extremely careful attention is paid to pipe bedding installation.

#### GUIDELINE

- ⊕ Depth of cover over flexible pipe shall be 3 feet minimum and 15 feet maximum. Where the depth of cover over a pipe is less than 3 feet or exceeds 15 feet, follow pipe manufacturer's recommendations for pipe material type and class, pipe installation procedures, bedding and backfill.
- ⊕ Testing and inspection: Full time inspection of pipe bedding operation should be performed on flexible pipe installations over 15 feet.

#### POTENTIAL LOCAL AGENCY IMPACTS

- ⊕ Inspection of bedding operations to ensure proper installation is especially critical for deeply buried flexible pipe.
- ⊕ Inspection costs would go up for those agencies that are currently not continuously inspecting bedding placement for deeply buried flexible pipe.
- ⊕ Review of supporting calculations would be required when flexible pipe is used for installations over 15 feet.

#### POTENTIAL KING COUNTY IMPACTS

- ⊕ No impact since King County does not normally allow side sewer connections to its conveyance system.

#### POTENTIAL PRIVATE PROPERTY/RATEPAYER IMPACTS

- ⊕ Construction costs for deeply buried pipe may increase moderately, thus increasing costs to ratepayers, in those agencies that presently allow installation of flexible side sewer pipe at depths over 15 feet without an engineering analysis.

## **I/I CONTROL STANDARD TITLE: Allowable Connections to Side Sewers**

### **STANDARD NO. PRV-2**

#### **I/I CONTROL MEASURE ISSUE:**

Description of allowable and disallowable connections to side sewers for the purpose of eliminating clean surface and subsurface drainage flow to the public separate sewer systems discharging to the King County regional conveyance system.

#### **STANDARD**

- ⊕ Side sewers discharging to separated sewer systems shall convey sanitary sewage only. Sanitary sewage sources are limited to:
  - Building plumbing outlets.
  - Sump Pumps conveying sanitary sewage.
- ⊕ Sources of clean water flow shall not be conveyed by side sewers discharging to a separate sewer system, including:
  - Downspouts.
  - Foundation drains.
  - Catch basins.
  - Storm water inlets and trench drains.
  - Structure or landscaping under-drain systems.
  - Sump pumps discharging surface runoff or subsurface drainage flow.

#### **POTENTIAL LOCAL AGENCY IMPACTS**

- ⊕ Allowable connections to side sewers shall be in conformance with applicable plumbing codes.
- ⊕ Newly developing building sites will be required to establish separate surface and sub surface drainage systems compatible with the developed site grading, soil conditions, groundwater table, and adjacent environmentally sensitive areas. Comprehensive monitoring for disallowable side sewer connections will be required, particularly where alternate disposal requirements for drainage are onerous to the property owner.
- ⊕ It is expected that some existing building sites will be found to be discharging clean water to the side sewer, either as a result of partial failure of side sewers, or as a result of illicit connections. When implementing corrective measures for these sites, consideration must be given to disposition of the resulting displaced flows. New site drainage systems implemented for this purpose must be compatible with the developed site grading, soil conditions, groundwater table, and adjacent environmentally sensitive areas.
- ⊕ Requirements for newly developing sites are consistent with most current development regulations and should not result in development costs above and beyond current requirements.
- ⊕ Repair of failed side sewers will result in varying levels of cost on a per site basis. Incremental cost impacts will be associated with the following factors:
  - Side sewer length.
  - Site development features (i.e. structures, landscaping, pavement, etc.).
  - Site accessibility (i.e. slope, overgrowth, sensitive areas, etc.).
- ⊕ Disconnection of clean water sources from side sewers on developed sites will result in varying levels of cost on a per site basis. Incremental cost impacts will be associated with the following factors:
  - Distance to alternative discharge point for clean water flows.
  - Presence of environmentally sensitive areas.
  - Relative elevation of property to alternative discharge point.
  - Ground water elevation.
  - Site elevation relative to surrounding areas.
  - Proportion of impermeable area on the site.

- ⊕ Testing to determine the presence of failed side sewer conditions that might allow clean water to enter the system cannot be comprehensively achieved except during wet weather conditions that result in saturated ground conditions. Testing for this purpose is best achieved on a basin wide basis through flow monitoring and analysis, or potentially through television inspection.
- ⊕ Testing for illicit downspout connections and certain area drain connections can be achieved, under favorable conditions, through smoke testing. Some illicit connections of surface or subsurface drainage will not be detected through smoke testing, but might be detectable using dye testing.
- ⊕ Generally, basin wide testing for illicit connections is implemented prior to the implementation phase to determine where remedial actions may be required. Site specific testing during implementation of the remedial work may be helpful in determining the effectiveness and completeness of the work being undertaken.

**POTENTIAL KING COUNTY IMPACTS**

⊕

**POTENTIAL PRIVATE PROPERTY/RATEPAYER IMPACTS**

⊕

**I/I CONTROL GUIDELINE TITLE: Pipe Zone Bedding and Trench Backfill**

**GUIDELINE NO. PRV-3**

**I/I CONTROL MEASURE ISSUE:**

Side sewers not laid in granular bedding material are subject to potential point loading and/or deflection over time leading to subsequent damage to the pipe or pipe joint.

**GUIDELINE**

⊕ Side sewer/lateral pipe zone bedding material shall provide uniform support along the entire pipe barrel, without load concentration at joint collars or bells. Bedding material shall be granular material meeting the requirements of Standard Detail S-1. The installed pipe zone bedding material shall effectively separate the side sewer from contact with the native ground and any rocks, pebbles, roots, or other materials that might impose a point load on the side sewer. The pipe zone bedding material shall extend a minimum of 4 inches beyond the outside dimension of the side sewer pipe in all directions. All adjustments to line and grade shall be made by scraping away bedding material or filling with bedding material under the body of the pipe and not be accomplished by blocking or wedging. Disturbed bedding shall be reconsolidated prior to backfill. Pipe zone bedding material shall be compacted to 95 percent maximum density per ASTM D-1557. Bedding shall be placed, spread, and compacted before the pipe is installed so that the pipe is uniformly supported along the barrel. Material shall be worked carefully under and around the pipe haunches and then compacted.

⊕ Deviation from the installation requirements noted above is acceptable where written recommendations have been provided by the pipe manufacturer.

**POTENTIAL LOCAL AGENCY IMPACTS**

⊕ Site inspection of side sewer bedding and backfill material and installation will be required to insure that requirements are met. Local Agency may be sewer agency or building department.

⊕ Additional inspection and review time would be required for those Local Agencies not currently inspecting side sewer installations and reviewing material submittals.

**POTENTIAL KING COUNTY IMPACTS**

⊕ No impact, since King County does not allow side sewer connection to its conveyance system.

**POTENTIAL PRIVATE PROPERTY/RATEPAYER IMPACTS**

⊕ Potentially higher costs if builder/developer does not now use good practices in installing side sewers.

⊕ Potentially higher permit costs for inspections and testing.

**I/I CONTROL GUIDELINE TITLE: Pipe Materials**

**GUIDELINE NO. PRV-4**

**I/I CONTROL MEASURE ISSUE:**

Pipe breakage and joint failures may occur because of improperly selected side sewer/lateral pipe materials and/or installation procedures, resulting in infiltration. Proper selection of pipe materials and joint systems is an important component of side sewer design and construction that will result in reduced immediate and future infiltration.

**GUIDELINE**

⊕ Side sewer/lateral pipe materials shall be selected based on external loading and soil corrosion potential. Pipe materials used shall have strength characteristics consistent with the earth load and surcharge conditions anticipated. Vehicle live loads, overburden, soil characteristics, and slope conditions shall be considered. Side sewers shall be installed below the frost line and at a depth consistent with the published load bearing capacity of the pipe material used. Pipe materials used shall have corrosion resistant characteristics consistent with the corrositivity of the environment in which they are to be installed.

⊕ Side sewer/lateral pipe materials shall employ gasketed joints and standard manufactured fittings designed for use with the pipe material installed. Deflection of joints shall be limited to 80% of the published maximum deflection for the gasketed joint. Flexible pipe materials used shall be properly bedded and backfilled to ensure that deflection of the pipe beyond its structural capacity will not occur and that deflection “out of round” beyond the capability of the pipe joints to remain sealed does not occur.

⊕ Connection between the side sewer/lateral and dissimilar building plumbing piping shall be accomplished using approved flexible water tight couplings specifically designed for the pipe materials joined. Butt joints wrapped and/or encased in concrete or mortar joint will not be allowed. Connection of pressure discharges from building plumbing to gravity side sewers/laterals shall be accomplished using standard pressure fittings and shall be anchored to ensure against movement during pressurization cycles.

**POTENTIAL LOCAL AGENCY IMPACTS**

⊕ Site inspection of side sewer/lateral material and joint installation insuring requirements are met. Local Agency may be sewer agency or building department.

⊕ Additional inspection and review time would be required for those Local Agencies not currently inspecting side sewer installations and reviewing material submittals.

⊕ Integrity of the installed pipe material and joints must be determined through water, air, or vacuum testing (see testing standards). Testing to confirm integrity of side sewers/laterals should be required prior to acceptance of the installation following construction and following a one-year warranty period.

**POTENTIAL KING COUNTY IMPACTS**

⊕ No impact, since King County does not normally allow side sewer connection to its conveyance system.

**POTENTIAL PRIVATE PROPERTY/RATEPAYER IMPACTS**

⊕ May be added costs to property owner/developers if their practices change due to standards for pipe material and joint systems being more strictly enforced.

## I/I CONTROL STANDARD TITLE: Inspection Wyes/Cleanouts

### STANDARD NO. PRV-5

#### I/I CONTROL MEASURE ISSUE:

Pipe breakage and joint failures may occur during the service life of a side sewer pipe, resulting in infiltration. Installation of inspection wyes/cleanouts at the upstream end of the side sewer allows for the future preparation and inspection of side sewer to identify infiltration problems and their specific sources.

#### STANDARD

⊕ An inspection wye/cleanout shall be installed in each new and rehabilitated side sewer immediately down stream of the connection between the building plumbing outlet and the side sewer per Standard Detail SS-1. The inspection wye/cleanout shall meet the requirements of Standard Detail SS-4. Inspection wyes/cleanouts shall be installed no less than 2 feet and no more than 5 feet beyond the face of the building for new side sewer installations. For rehabilitation projects, the inspection wye/cleanout shall be located within 2 feet of the termination of the rehabilitation. Inspection wyes/cleanouts shall be located, to the greatest extent possible, to ensure CCTV accessibility in the future throughout the entire side sewer.

⊕ When any work is done to rehabilitate a side sewer that involves excavating to expose and gain entry to the pipe outside of an existing inspection wye/cleanout, the entire side sewer from the property line to the building(s) must be upgraded to meet this standard.

⊕ Connection of inspection wye/cleanout assemblies to the existing pipe system shall be made with an approved rubber gasketed pipe coupling.

#### POTENTIAL LOCAL AGENCY IMPACTS

⊕ Inspection of inspection wye/cleanout installations to ensure that requirements are met. Local Agency may be sewer agency or building department. Documentation and record keeping to facilitate future location and use of the inspection wyes/cleanouts.

⊕ Property access issues allowing use of inspection wyes/cleanouts by the Local Agency and/or the sewer agency to assess condition of the side sewer/lateral in the future. May require side sewer permit/utility ordinance clause modifications.

⊕ Additional administrative costs to initially record and maintain records of inspection wye/cleanout locations.

⊕ Additional costs associated with permit language and/or ordinance modifications required to establish legal right for Local Agency to access inspection wyes/cleanouts on private property.

⊕ Additional cost associated with ongoing program of periodic monitoring of side sewer integrity and performance using the inspection wyes/cleanouts.

⊕ Inspection wye/cleanout testing will be accomplished integrally with the side sewer/lateral test.

#### POTENTIAL KING COUNTY IMPACTS

⊕ No impact, since King County does not normally allow side sewer connections to its conveyance system.

#### POTENTIAL PRIVATE PROPERTY/RATEPAYER IMPACTS

⊕ Increased costs for added fittings and installation requirements, as well as inspections where standard requirements exceed current requirements

⊕ Restrictions on development and landscaping required to maintain accessibility to inspection wye/cleanout in the future.

## **I/I CONTROL GUIDELINE TITLE: Lateral and Side Sewer Rehabilitation Methods**

### **GUIDELINE NO. PRV-6**

#### **I/I CONTROL MEASURE ISSUE:**

Once the decision has been made to rehabilitate laterals or side sewers to control I/I, several alternatives may be used to replace or rehabilitate the pipe. These include trenchless rehabilitation techniques such as cure-in-place lining, pipe bursting and conventional dig and replace. An evaluation should be made to determine suitability (technical and cost effectiveness) of trenchless methods versus conventional dig and replacement of the sewer. The technical evaluation should assess specific issues such as the sewer location and length, alignment, condition of the pipe being replaced, assessment of the surface features that would be disturbed by construction, and the degree of root intrusion in the existing lines. The alternative pipe rehabilitation methods that should be considered include:

Pipe bursting is a trenchless pipeline rehabilitation method that can be used to replace side sewer pipes. Reduction of excess flow is achieved by eliminating sources of infiltration in the piping being replaced. Illicit connections are eliminated by removing the connection to the side sewer. It is possible to increase the size of the pipe; however, site specific constraints may limit the ability to increase the size. Using pipe bursting to replace a pipe may be restricted depending upon adjacent utilities, proximity to surface improvements, the type of existing pipe being replaced, and soil conditions. There are a number of variations on pipe bursting, such as pneumatic, hydraulic expansion, and static pull systems. All of these displace the old pipe into the adjacent ground and pull a new pipe in to replace the old pipe. There are also related processes such as pipe reaming, which is a variation of horizontal directional drilling, where pieces of the old pipe are removed rather than pushing them into the adjacent soil. The most common pipe material used is HDPE, but other types of pipe material such as cast iron, MDPE, and ABS can be used for the replacement pipe. Pipe bursting of side sewers will require excavation of at least two pits for insertion and pulling. Generally, pipe bursting is suitable for straight sections. If there are buried bends on the side sewer it may require additional pits to be excavated for installation of the replacement pipe.

Cure-in-place pipe (CIPP) liner is a trenchless pipeline rehabilitation method that can be used to repair existing side sewer pipes. Reduction of excess flow is achieved by eliminating sources of infiltration in the piping being rehabilitated. CIPP liner involves inverting an epoxy-resin-impregnated flexible tube into an existing line using hydrostatic head. The resin is then cured using heat to produce a pipe inside the existing side sewer. The outside diameter of the replacement pipe is smaller than the existing pipe to allow the system to be installed. Capacity in the pipeline will be reduced because of the reduction in pipe size.

Fold and form lining is a trenchless pipeline rehabilitation method that can be used to repair existing side sewer pipes. Reduction of excess flow is achieved by eliminating sources of infiltration in the piping being replaced. The fold-and-form process involves inserting a heated PVC or HDPE thermoplastic liner, folded or deformed into a U-shape, into an existing side sewer and re-rounding the liner using heat and pressure to produce a pipe inside the existing pipe. The outside diameter of the replacement pipe is smaller than the existing pipe to allow the system to be installed. Capacity in the pipeline will be reduced because of the reduction in pipe size.

#### **GUIDELINE**

- ⊕ Construction standards for pipe bursting, cure-in-place lining and folded and formed liners shall be as follows:
  - ⊕ Pipe Bursting:
    - Pipe bursting shall meet the requirements of the King County Regional Inflow and Infiltration Control Program Guide Specifications.
  - ⊕ Cure-in-Place Lining:

<ul style="list-style-type: none"><li>• Cure-in-place-lining shall meet the requirements of the King County Regional Inflow and Infiltration Control Program Guide Specifications.</li></ul> <p>⊕ <u>Fold and Form:</u></p> <ul style="list-style-type: none"><li>• Fold and form-lining shall meet the requirements of the King County Regional Inflow and Infiltration Control Program Guide Specifications.</li></ul> <p>⊕ <u>Testing and Inspection:</u></p> <ul style="list-style-type: none"><li>• The rehabilitated side sewer/lateral from the inspection wye/cleanout at the building foundation to the main side sewer/lateral pipeline shall be tested in accordance with the I/I Side Sewer/Lateral Leak Testing Standard, and shall be television inspected in accordance with the I/I CCTV Inspection Standard after completion of the repairs and backfilling of the pipe trench.</li></ul>
<p><b>POTENTIAL LOCAL AGENCY IMPACTS</b></p> <p>⊕ Added cost to perform inspection and testing.</p>
<p><b>POTENTIAL KING COUNTY IMPACTS</b></p> <p>⊕ No impact, since King County does not normally allow side sewer connections to its conveyance system.</p>
<p><b>POTENTIAL PRIVATE PROPERTY/RATEPAYER IMPACTS</b></p> <p>⊕ Added cost for inspection and testing of private sewer lines.</p>

**I/I CONTROL STANDARD TITLE: Spot Repairs**

**STANDARD NO. PRV-7**

**I/I CONTROL MEASURE ISSUE:**

Private side sewer spot repairs are repairs to specific deficiencies in a side sewer pipe, such as a specific leaking pipe joint. These repairs can be a cost effective way to eliminate I/I in sections (generally cleanout-to-cleanout that show damage) of a side sewer that are sound except for a few point locations. Only those specific deficiencies in the side sewer are repaired. In sections with numerous spot problems or with other mitigating factors such as age, the entire side sewer is a candidate for complete rehabilitation or replacement.

**STANDARD**

- ⊕ As a precursor to doing spot repairs, the Local Agency shall assess the age and material of the side sewer to determine if it should be completely replaced rather than allow spot repairs. If a side sewer is over 50 years old, it shall be completely rehabilitated or replaced from the building to the public right-of-way.
- ⊕ Spot repairs can be accomplished by several different methods from trenchless systems like CIPP liners, injecting epoxy resins, or chemical grout, to dig and repair with structural grouting sleeves or short sections of pipe replacement. The repair method shall address whether the defect is structural or limited to an intact leaky joint.
- ⊕ For a dig and replace spot repair, the section of the side sewer shall be removed to the nearest joint and replaced with new pipe meeting the requirements of the I/I Pipe Materials Standard. The new section of pipe shall be installed with approved repair couplings.
- ⊕ Trenchless spot repairs shall meet the I/I standard for the particular rehabilitation method used.
- ⊕ Inspection wye/cleanouts shall be installed on the side sewer per Standard Detail SS-1 as part of the spot repair.

**POTENTIAL LOCAL AGENCY IMPACTS**

- ⊕ Cost of installing the inspection wye/cleanout on public right-of-way if none exists.

**POTENTIAL KING COUNTY IMPACTS**

- ⊕ No impact, since King County does not normally allow side sewer connection to its conveyance system.

**POTENTIAL PRIVATE PROPERTY/RATEPAYER IMPACTS**

- ⊕ Added cost will be incurred if no inspection wye/cleanout exists in the system.

**I/I CONTROL STANDARD TITLE: Root Intrusion**

**STANDARD NO. PRV-8**

**I/I CONTROL MEASURE ISSUE:**

Side sewers that have roots protruding in the pipe have a breach in the piping system either at a joint and/or a break in the pipe. This breach is a potential source for infiltration.

**STANDARD**

⊕ For any sewer system rehabilitation work on side sewers or laterals that utilizes public resources, root intrusion shall be addressed by evaluating removal of the roots and repair or replacement of the side sewer/lateral at the point of root intrusion.

**POTENTIAL LOCAL AGENCY IMPACTS**

⊕ The costs of pipe repair will be incurred if the rehabilitation is financed by the agency.

**POTENTIAL KING COUNTY IMPACTS**

⊕ No impact, since King County is not responsible for side sewers.

**POTENTIAL PRIVATE PROPERTY/RATEPAYER IMPACTS**

⊕ Pipe repair activities may cause inconveniences from service disruptions or construction activities.

⊕ The cost of rehabilitation will be incurred if financed by the property owner.

**I/I CONTROL STANDARD TITLE: Side Sewer/Lateral Leak Testing**

**STANDARD NO. PRV-9**

**I/I CONTROL MEASURE ISSUE:**

Several aspects of side sewer/lateral pipe installation, if not properly designed and constructed, may result in infiltration entering the finished pipeline. Leakage testing of the assembled side sewer/lateral immediately following construction is the final opportunity for verification that the pipeline meets acceptable I/I criteria prior to being placed into service.

It is also beneficial to test side sewer/lateral pipelines after a significant period of service to confirm that as-built conditions have not degraded due to material failures, bedding or backfill settlement, or other causes.

**STANDARD**

⊕ Acceptance criteria following construction shall include testing requirements to ensure that the side sewer/laterals and connections of new and rehabilitated side sewers/laterals, as constructed, meet specified leakage limitations. All new side sewer/laterals shall be tested by either a water test or a low pressure air test.

⊕ The water test shall be an infiltration test if the side sewer/lateral is installed below the groundwater level. The water test shall be an exfiltration test if the side sewer/lateral is installed above the groundwater level. Testing shall be in conformance with WSDOT/APWA Standard Specifications. The downstream end of the private side sewer/lateral shall be plugged to isolate the private side sewer/lateral from the public side sewer/lateral stub and the building plumbing when water testing methods are employed.

⊕ Low pressure air testing shall conform to the requirements of the WSDOT/APWA Standard Specifications. The downstream end of the private side sewer/lateral shall be plugged to isolate the private side sewer/lateral from the public side sewer/lateral stub and the building plumbing when low-pressure air testing methods are employed.

⊕ Where a rehabilitated lateral/side sewer cannot be water tested or low pressure air tested, the pipeline shall be CCTV inspected for leakage at its connection point to the sewer main. The inspection for leakage shall be performed during the wet season when surrounding soils are fully saturated.

⊕ On publicly funded rehabilitation projects, additional testing at the completion of the warranty period to establish the continued integrity of the side sewer/lateral shall be required. Since water testing or low-pressure air testing of side sewer/laterals after they have been put into service is problematic, visual inspection using CCTV shall be conducted as the most effective practical testing method available for confirming that warranty requirements have been met.

**POTENTIAL LOCAL AGENCY IMPACTS**

- ⊕ Possible additional cost and additional staffing requirements for acceptance and warranty testing verification.
- ⊕ Possible additional construction cost to account for acceptance and warranty testing requirements.
- ⊕ Potential additional cost for agency to conduct Video Inspection and/or review Video Inspection tapes at the end of the warranty period.

**POTENTIAL KING COUNTY IMPACTS**

- ⊕ No impact since King County does not normally allow side sewer connections to its conveyance system.

**POTENTIAL PRIVATE PROPERTY/RATEPAYER IMPACTS**

⊕ Increased permit costs for added testing requirements, as well as inspections, where standard requirements exceed current requirements.

**I/I CONTROL GUIDELINE TITLE: Sanitary Side Sewer Inspection**

**GUIDELINE NO. PRV-10**

**I/I CONTROL MEASURE ISSUE:**

A visual inspection of the private side sewer is needed before it is backfilled or covered to ensure that pipe materials meet specifications, the pipe is properly supported, and that storm water drains and subsoil drains are not connected to the sanitary sewer.

**GUIDELINE**

⊕ No trench shall be filled nor any side sewer covered until the work has been inspected, tested and approved by the Local Agency. The Local Agency may require that any work covered be uncovered, or tested by a recognized independent testing laboratory (at the expense of the permittee), to ensure that the work has been accomplished in accordance with the permit.

**POTENTIAL LOCAL AGENCY IMPACTS**

⊕ Inspection standards for private side sewers would need to include a provision for a visual inspection of each side sewer before it is backfilled or covered. Additional inspection effort would be required for those agencies not currently inspecting each side sewer. Local Agency inspection forms should include verification of the visual inspection including date, time and the name of the inspector.

⊕ Tighter coordination of inspection timing may be required.

⊕ Additional inspection time would be required for those agencies not currently inspecting each side sewer.

**POTENTIAL KING COUNTY IMPACTS**

⊕ No impact since King County does not normally allow side sewer connections to its conveyance system.

**POTENTIAL PRIVATE PROPERTY/RATEPAYER IMPACTS**

⊕ Permit fees for side sewer installation could increase for Local Agency to finance inspection costs.

**I/I CONTROL STANDARD TITLE: Sanitary Side Sewer CCTV Requirements**

**STANDARD NO. PRV-11**

**I/I CONTROL MEASURE ISSUE:**

Television inspection of newly installed and rehabilitated side sewers provides documentation of connections, confirms pipe joints are properly pushed home, and identifies infiltration defects and inflow sources.

**STANDARD**

⊕ A televised inspection of the connection of new and rehabilitated lateral/side sewers to the sewer main shall be performed where the lateral/side sewer cannot be pressure tested. An audio-visual tape recording of the inspection, compatible with the Local Agency’s existing audio-visual format, shall be retained by the Local Agency. The television inspection shall be conducted following trench backfill and compaction, cleaning and testing. If dewatering was required for side sewer installation, the groundwater level shall be allowed to return to its normal elevation before performing the inspection.

**POTENTIAL LOCAL AGENCY IMPACTS**

- ⊕ Additional inspection time to CCTV the lateral/side sewer and connection would be required for those agencies performing their own CCTV inspections.
- ⊕ Equipment costs for new CCTV camera equipment capable of inspecting lateral/side sewers may be required.
- ⊕ An increase in lateral/side sewers costs will result for agencies that do not currently require the contractor to perform CCTV inspections.

**POTENTIAL KING COUNTY IMPACTS**

- ⊕ No impact since King County does not normally allow side sewer connections to its conveyance system.

**POTENTIAL PROPERTY OWNER/RATEPAYER IMPACTS**

- ⊕ CCTV inspection requirements will increase the total cost of lateral/side sewer installations.

**I/I CONTROL STANDARD TITLE: Product Specific Inspection**

**STANDARD NO. PRV-12**

**I/I CONTROL MEASURE ISSUE:**

Side sewer system products in both new and rehabilitation improvements can fail and lead to I/I due to improper installation and/or non-specified products being installed. Without inspection, there are no assurances the product installed is the one specified and was installed properly.

**STANDARD**

- ⊕ Product inspection is the visual verification of product test results and/or confirmation that an approved product is the one being installed, and the sequence of construction or application is appropriate. All products being installed shall be inspected to verify the approved product is being installed in accordance with approved specifications. This includes pipe, fittings, bedding, and rehabilitation products. It is important to distinguish the difference between inspection and testing. Those products covered under the testing standard shall have those tests performed to verify compliance.
- ⊕ Pipe shall be inspected at the point of installation to verify that it has factory markings identifying the type and class of pipe. Unlabeled products will not be approved for installation.
- ⊕ Pipe fittings shall be inspected at the point of installation to confirm they meet the specifications.
- ⊕ Pipe bedding material shall be inspected at the time of installation to confirm the material is appropriate for the type of pipe (flexible or rigid).
- ⊕ For rehabilitation products, the manufacturer’s recommended installation procedure shall be reviewed prior to installation. An installation list with references shall be provided documenting recent projects where the product has been installed recently. The Local Agency shall contact references and document the installation and operational experiences with the product, and conduct any additional investigations determined necessary for approval of the product and installation. If through this review the product appears acceptable, the installation requirements shall be documented from the review process along with any testing requirements of the installation.

**POTENTIAL LOCAL AGENCY IMPACTS**

- ⊕ Added cost for increased inspection.
- ⊕ Additional qualification investigation for proposed rehabilitation products.

**POTENTIAL KING COUNTY IMPACTS**

- ⊕ No impact since King County does not normally allow side sewer connections to its conveyance system.

**POTENTIAL PRIVATE PROPERTY/RATEPAYER IMPACTS**

- ⊕ Potential for increased inspection costs.
- ⊕ Possible extension of construction schedule to accommodate inspection requirements.

**I/I CONTROL STANDARD TITLE: Product Specific Certification**

**STANDARD NO. PRV-13**

**I/I CONTROL MEASURE ISSUE:**

Some new construction and/or rehabilitation products or application systems may not have a proven track record of performance, yet offer attractive benefits or low costs which merit their use. The contractor installing the product must also be approved by the supplier as qualified to perform the work. A product specific certification can be used to protect the property owner’s investment and the Local Agency’s long-term interest.

**STANDARD**

- ⊕ When a new construction and/or rehabilitation product or application system does not have a documented record of comparable prior successful installations, the supplier of the product or system shall be required through the building or sewer connection permit process to provide certification that the product or system will perform as specified.
  - The contractor installing the rehabilitation product shall be certified by the product manufacturer as being qualified to apply/install the product.
  - The certification shall provide for the complete replacement of the product or system by the contractor if the product or system is found to be defective.

**POTENTIAL LOCAL AGENCY IMPACTS**

- ⊕ Staff or consultant Engineer will need to spend time to research and develop a certification period as well as a means for determining compliance.
- ⊕ Inspection during construction to monitor installation/application will increase staffing requirements.
- ⊕ Follow-up time by staff to monitor product or system performance may delay project completion and may increase staff requirements.
- ⊕ Potential for additional project cost by manufacturer or contractor.
- ⊕ Additional engineering cost during design, construction and follow-up will likely be incurred.

**POTENTIAL KING COUNTY IMPACTS**

- ⊕ No impact since King County does not normally allow side sewer connections to its collection system.

**POTENTIAL PRIVATE PROPERTY/RATEPAYER IMPACTS**

- ⊕ Potentially higher side sewer construction costs for certifications.

**I/I CONTROL STANDARD TITLE: Bonding and Warranty Inspection**

**STANDARD NO. PRV-14**

**I/I CONTROL MEASURE ISSUE:**

One critical element of a warranty is verification of the improvement prior to the end of the warranty period so that construction deficiencies can be accomplished and paid for via the performance bond. Thus the system can be repaired and I/I eliminated.

**STANDARD**

- A warranty period shall be established on publicly funded projects for each side sewer project, or for each project containing a side sewer construction component. This warranty period shall be a minimum of one year in length.
- All side sewer pipes shall be CCTV inspected after 80% of the warranty period has expired but before the end of the warranty period. Defective portions of the system shall be repaired to meet all applicable I/I standards.
  - ⊕ A written record shall be made by the agency of acceptance of the improvement with the date and results of the inspections and testing. This shall be submitted to Contracting Agency for concurrence prior to release of the performance bond.

**POTENTIAL LOCAL AGENCY IMPACTS**

- ⊕ Additional CCTV inspection and enforcement of the warranty.

**POTENTIAL KING COUNTY IMPACTS**

- ⊕ Processing time for concurrence to release performance bond.

**POTENTIAL PRIVATE PROPERTY/RATEPAYER IMPACTS**

- ⊕ Potential of added costs for inspections and verifications.
- ⊕ Possible schedule delay to allow for verifications.



MWPAAC Engineering & Planning Subcommittee

**FINAL DRAFT**

**Standard Details**



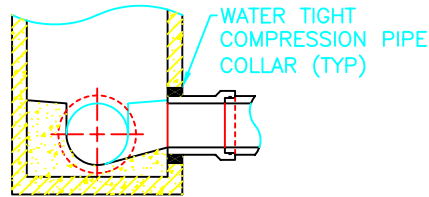
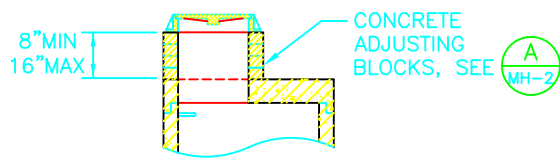

**NOTES:**

1. JOINT BETWEEN PRECAST RISER AND CAST IN PLACE BASE SLAB SHALL BE WATERTIGHT. SEE (D) --
2. JOINT BETWEEN PRECAST RISER AND PRECAST BASE SHALL BE GASKETED. SEE (E) --
3. PATCH ALL LIFTING HOLES TO PROVIDE WATERTIGHT SEAL.

**TYPICAL REDUCING SLAB** (A) --  
SCALE: NTS

**PIPE PENETRATION DETAIL** 1 --  
SCALE: NTS

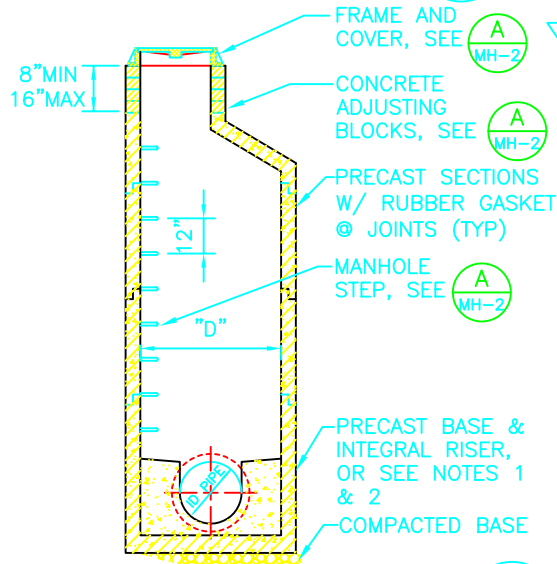

OPENINGS FOR PIPE CONNECTIONS SHALL BE PRECAST OR CORE DRILLED TO DIMENSION REQUIRED FOR COMPRESSION PIPE COLLAR (TYP)

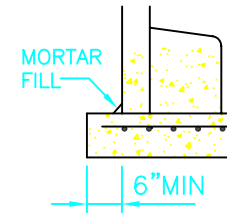
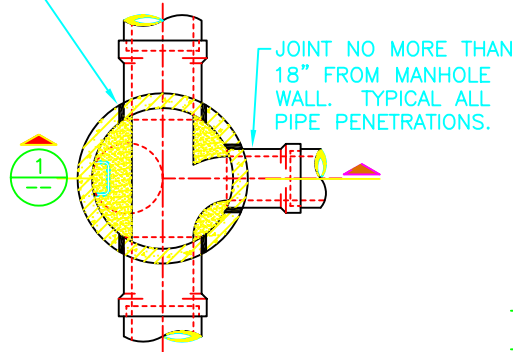

**CAST IN PLACE BASE JOINT** (D) --  
SCALE: NTS

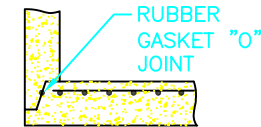

**PRECAST BASE JOINT** (E) --  
SCALE: NTS

**TYPICAL PRECAST MANHOLE** (B) --  
SCALE: NTS

**TYPICAL CONNECTION DETAIL** (C) --  
SCALE: NTS

THIS STANDARD ADDRESSES SPECIFIC FEATURES IMPACTING I/I CONTROL. SEE STANDARD DETAILS PUBLISHED BY ADMINISTRATIVE AUTHORITY FOR COMPLETE DESIGN REQUIREMENTS

**Regional Infiltration/Inflow Control Program**

**DRAFT**

**STANDARD I/I CONTROL FEATURES MANHOLES – NEW CONSTRUCTION**

DATE: SEP 04	DRAWN: TSM
DWG NO: <b>MH-1</b>	

MANHOLE FRAME  
AND COVER  
SEE NOTE 2

HANDHOLDS  
SEE NOTE 3

MANHOLE  
STEPS  
SEE NOTE 3

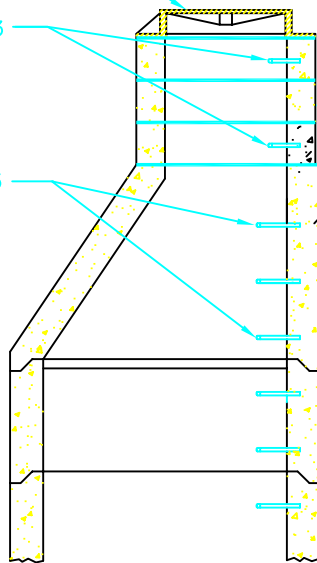

CONCRETE  
GRADE RING  
(TYP)  
SEE NOTE 1

NOTES:

1. INSTALL CONCRETE GRADE RINGS OF VARIABLE HEIGHT TO ALIGN MANHOLE FRAME AND COVER AT ELEVATION OF PAVEMENT SURFACE ABOVE PRECAST MANHOLE SEGMENTS.
2. LEVELING OF MANHOLE FRAME TO MATCH PAVEMENT SLOPE SHALL BE ACCOMPLISHED THROUGH A SINGLE COURSE OF NONSHRINK GROUT ABOVE THE UPPER CONCRETE GRADE RING AND SHALL MATCH THE FULL WIDTH OF THE GRADE RINGS. SOLID, GASKETED COVERS WITH WATERTIGHT SEAL SHALL BE USED WHEN MANHOLE RIM IS SUBJECT TO SURFACE WATER FLOW OR PONDING.
3. MANHOLE STEPS, HANDHOLES, AND OTHER ANCHOR BOLTS SHALL BE EMBEDDED IN PRECAST UNITS OR INSTALLED WITH CONCRETE ANCHORS. NO STEPS, HANDHOLDS OR ANCHORS SHALL PENETRATE THROUGH THE MANHOLE WALL.

GRADE RINGS, STEPS AND ANCHORS

SCALE: NTS



THIS STANDARD ADDRESSES SPECIFIC FEATURES IMPACTING I/I CONTROL. SEE STANDARD DETAILS PUBLISHED BY ADMINISTRATIVE AUTHORITY FOR COMPLETE DESIGN REQUIREMENTS

**Regional Infiltration/Inflow  
Control Program**

**DRAFT**

**STANDARD I/I CONTROL FEATURES  
MANHOLES – GRADE RINGS AND STEPS**

DATE:  
SEP 04

DRAWN:  
TSM

DWG NO:

**MH-2**

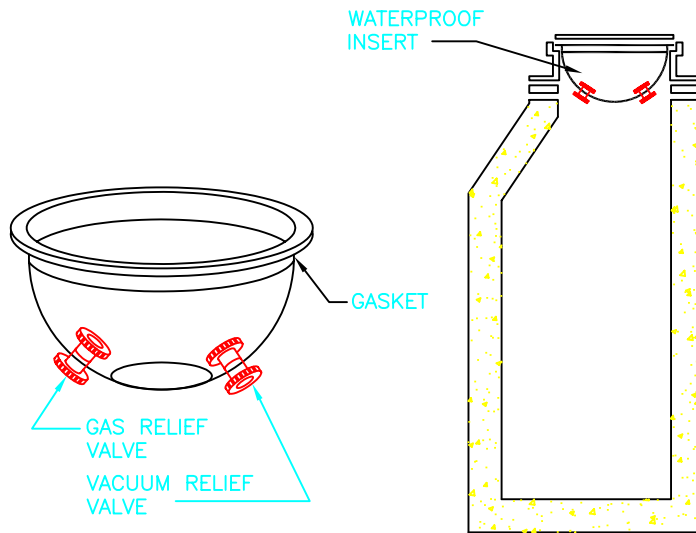

**MANHOLE COVER INSERT**

SCALE: NTS



**NOTES:**

1. THE INSERT SHALL BE DEEP ENOUGH TO PREVENT THE MANHOLE COVER FROM COMING IN CONTACT WITH THE VALVES WHEN THE MANHOLE COVER IS REMOVED OR INSTALLED.
2. THE INSERT WILL RESTRICT FLOW TO NO MORE THAN 1 GALLON IN 24 HOURS.
3. THE MANHOLE INSERT WILL BE MADE OF NON-CORRODABLE MATERIALS THAT WILL NOT BE DAMAGED BY SEWER GASES OR ROAD OIL.
4. THE GAS RELIEF VALVE AND THE VACUUM RELIEF SHALL BE SELF CLEANING AND BE MADE OF NON-CORRODABLE MATERIALS.
5. THE GAS RELIEF VALVE WILL BE AUTOMATICALLY ACTIVATED AT A PRESSURE DIFFERENTIAL OF APPROX. 2.25 PSI.
6. THE VACUUM RELIEF VALVE WILL BE AUTOMATICALLY ACTIVATED AT A PRESSURE DIFFERENTIAL OF APPROX. 2.25 PSI.
7. A GASKET SHALL BE INSTALLED UNDER THE LIP OF THE INSERT TO INSURE A TIGHT SEAL BETWEEN THE INSERT AND THE MANHOLE FRAME.
8. INSERTS NOT APPROPRIATE FOR USE ON MANHOLES WITH LOCKING COVERS.

THIS STANDARD ADDRESSES SPECIFIC FEATURES IMPACTING I/I CONTROL. SEE STANDARD DETAILS PUBLISHED BY ADMINISTRATIVE AUTHORITY FOR COMPLETE DESIGN REQUIREMENTS

**Regional Infiltration/Inflow Control Program**

**DRAFT**

**STANDARD I/I CONTROL FEATURES  
MANHOLE COVER INSERT**

DATE: SEP 04	DRAWN: TSM
DWG NO: <b>MH-3</b>	

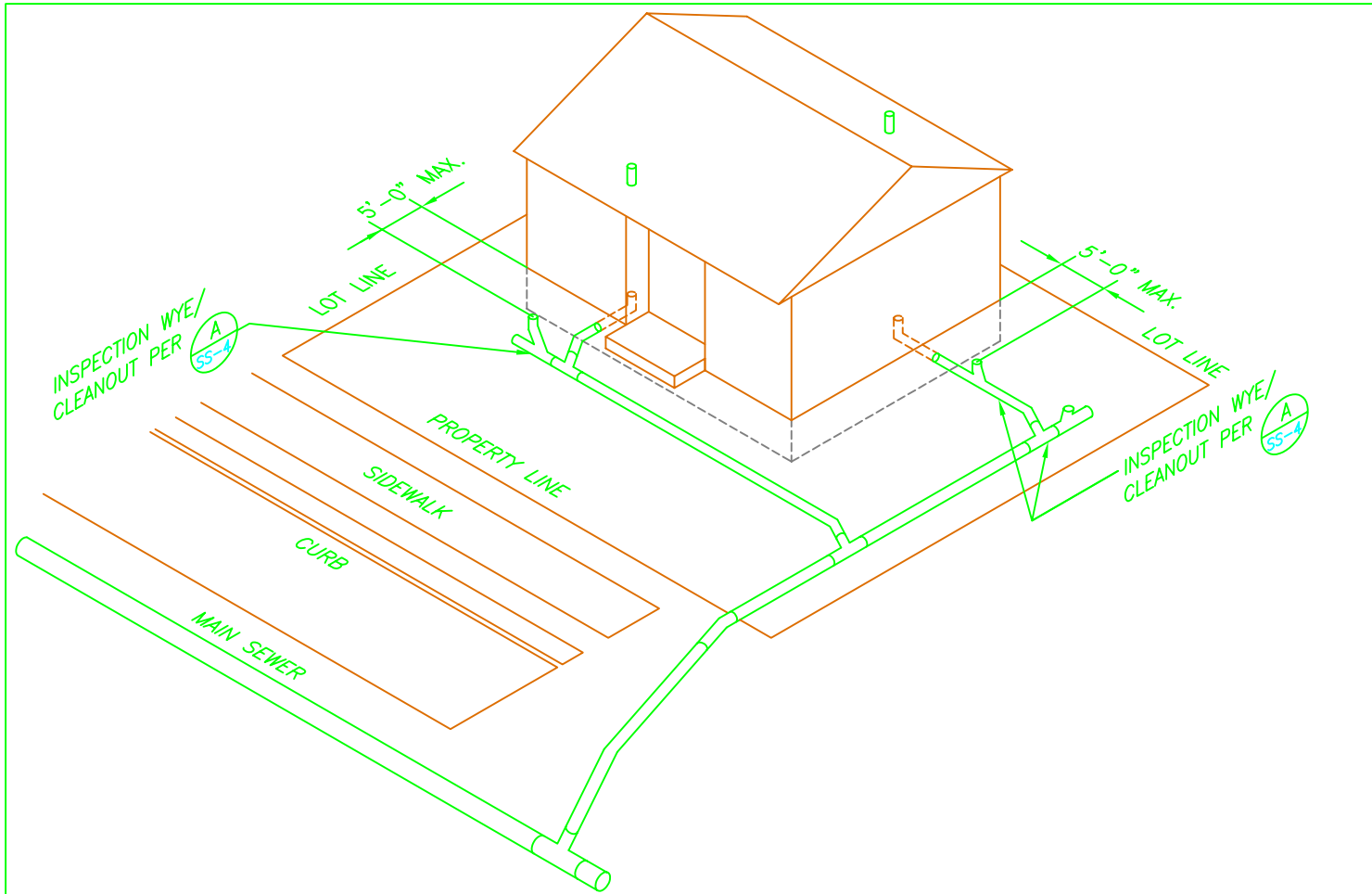

Regional Infiltration/Inflow  
Control Program

**DRAFT** STANDARD I/I CONTROL FEATURES  
SIDE SEWER INSTALLATION

DATE: SEP 04	DRAWN: TSM
DWG NO: <b>SS-1</b>	

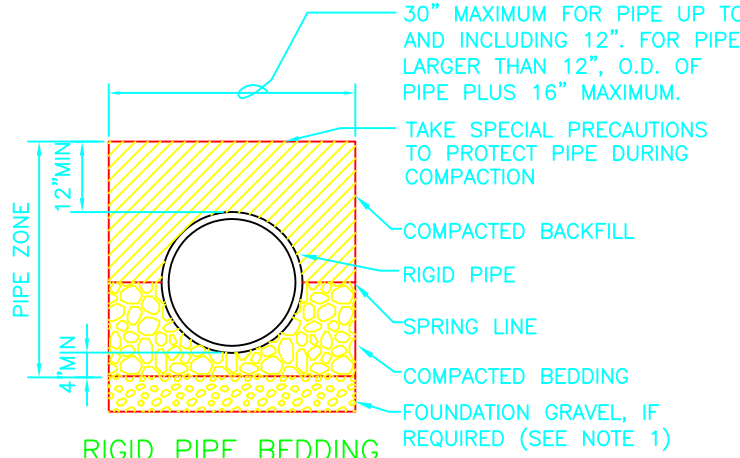

**RIGID PIPE BEDDING**

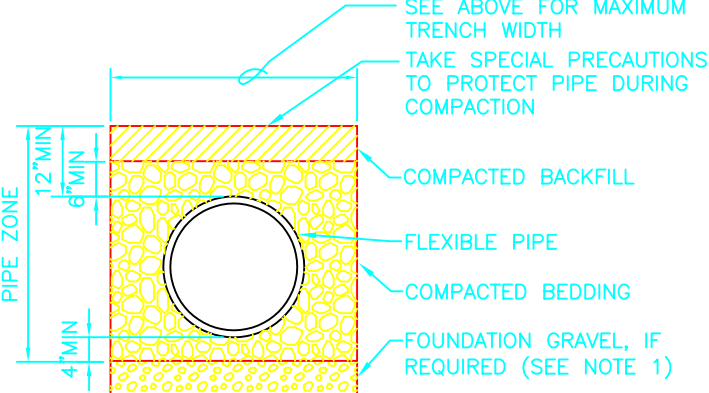

**FLEXIBLE PIPE BEDDING**

**PIPE BEDDING**

SCALE: NTS



**NOTES:**

1. EXCAVATE UNSTABLE MATERIAL DOWN TO FIRM SOIL AS DIRECTED BY THE ADMINISTRATIVE AUTHORITY AND REPLACE WITH FOUNDATION MATERIAL PER WSDOT/APWA SECTION 9-03.17 (FOUNDATION MATERIAL CLASS A)

**ALLOWABLE BEDDING MATERIALS\***

RIGID PIPE	FLEXIBLE PIPE
CRUSHED SURFACING TOP COURSE, SECTION 9-03.9 (3)	BEDDING MATERIAL FOR THERMO-PLASTIC PIPE, SECTION 9-03.16
GRAVEL BACKFILL FOR PIPE ZONE BEDDING, SECTION 9-03.12(3)	CRUSHED SURFACING TOP COURSE, SECTION 9-03.9(3)

\* BEDDING MATERIAL REQUIREMENTS PER WSDOT/APWA STANDARD SPECIFICATIONS.

\*THIS STANDARD ADDRESSES SPECIFIC FEATURES IMPACTING I/I CONTROL. SEE STANDARD DETAILS PUBLISHED BY ADMINISTRATIVE AUTHORITY FOR COMPLETE DESIGN REQUIREMENTS\*

**Regional Infiltration/Inflow Control Program**

**DRAFT**

**STANDARD I/I CONTROL FEATURES  
SEWER - PIPE ZONE BEDDING**

DATE: SEP 04  
DRAWN: JKL  
DWG NO: S-1

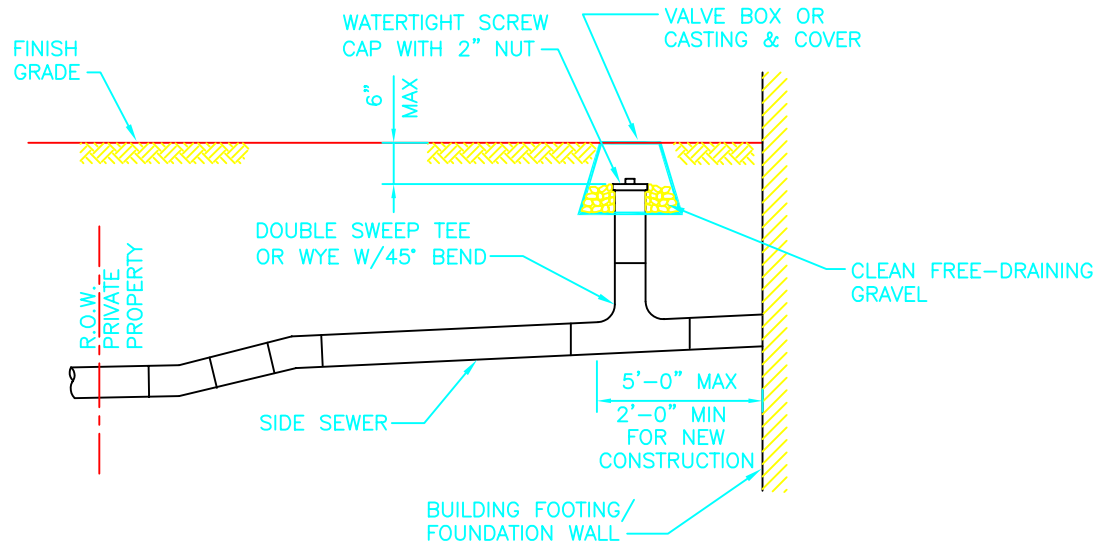

**SECTION**

**SIDE SEWER INSPECTION WYE/CLEANOUT** (A)

**NOTES:**

1. NO DOWNSPOUTS OR STORM DRAINAGE SHALL BE CONNECTED TO THE SANITARY SYSTEM.
2. AS-BUILTS DRAWING SHOWING LOCATION OF SIDE SEWER AND INSPECTION WYE/CLEANOUT IN RELATION TO THE HOUSE AND EXISTING UTILITIES IS REQUIRED AFTER INSTALLATION.
3. A CLEANOUT MAY BE HELD BELOW GRADE IN UNPAVED AREAS A MAXIMUM OF 6". PROVIDE AN 8"x8"x1/4" GALVANIZED STEEL PLATE OVER THE TOP OF BURIED CLEANOUTS FOR FUTURE LOCATING.
4. IF INSPECTION WYE/CLEANOUT IS WITHIN DRIVING SURFACE, EXTEND CLEANOUT TO GRADE AND PROVIDE AN HS-20 RATED LOAD-BEARING CASTING AND COVER.
5. FOR SIDE SEWER REHABILITATION PROJECTS, LOCATE INSPECTION WYE/CLEANOUT WITHIN 2 FEET OF THE TERMINATION OF THE REHABILITATED PIPE.

THIS STANDARD ADDRESSES SPECIFIC FEATURES IMPACTING I/I CONTROL. SEE STANDARD DETAILS PUBLISHED BY ADMINISTRATIVE AUTHORITY FOR COMPLETE DESIGN REQUIREMENTS

**Regional Infiltration/Inflow Control Program**

**DRAFT**

**STANDARD I/I CONTROL FEATURES  
SIDE SEWER INSPECTION WYE/CLEANOUT**

DATE: SEP 04	DRAWN: TSM
DWG NO: <b>SS-2</b>	

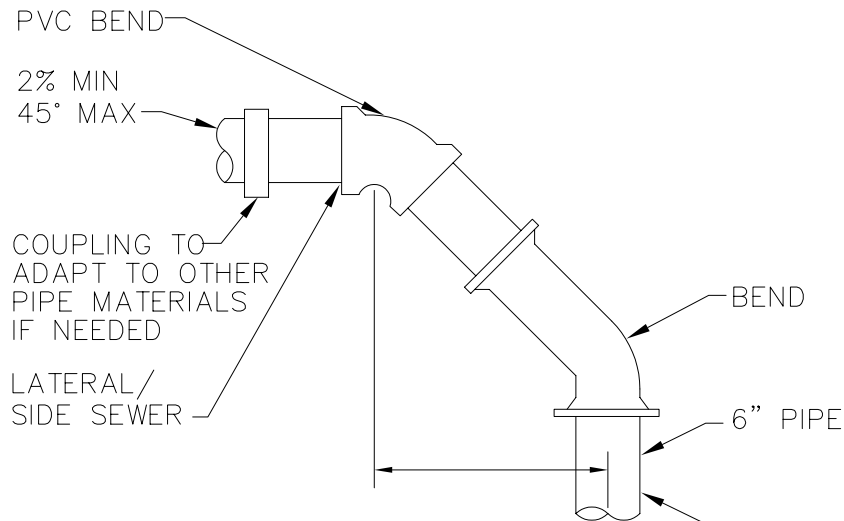

NOTES:

1. PIPE AND FITTINGS SHALL BE PVC PER ASTM D3034 SDR 35
2. PVC TEE INSERTS SHALL BE BY "INSERT A TEE" OR EQUAL AND SHALL INCLUDE RUBBER SLEEVE, PVC ADAPTER HUB AND STAINLESS STEEL BAND. INSERT SHALL BE INSTALLED IN A CORE DRILLED HOLE PER MANUFACTURER'S INSTRUCTIONS. INSERT SHALL BE FLUSH WITH THE INSIDE WALL OF THE MAIN.
3. LOCATE EDGE OF CORE DRILLED HOLE 1'-0" MINIMUM FROM EXISTING PIPE JOINT AND 2'-0" FROM THE EDGE OF ANY EXISTING OR NEW CONNECTIONS.
4. VERTICAL CONNECTION SHALL NOT BE USED UNLESS DEPTH FROM SURFACE TO TOP OF PIPE IS 20'-0" OR GREATER.
5. CONCRETE HAUNCHING IS TO BE CLASS 3000 CONCRETE.

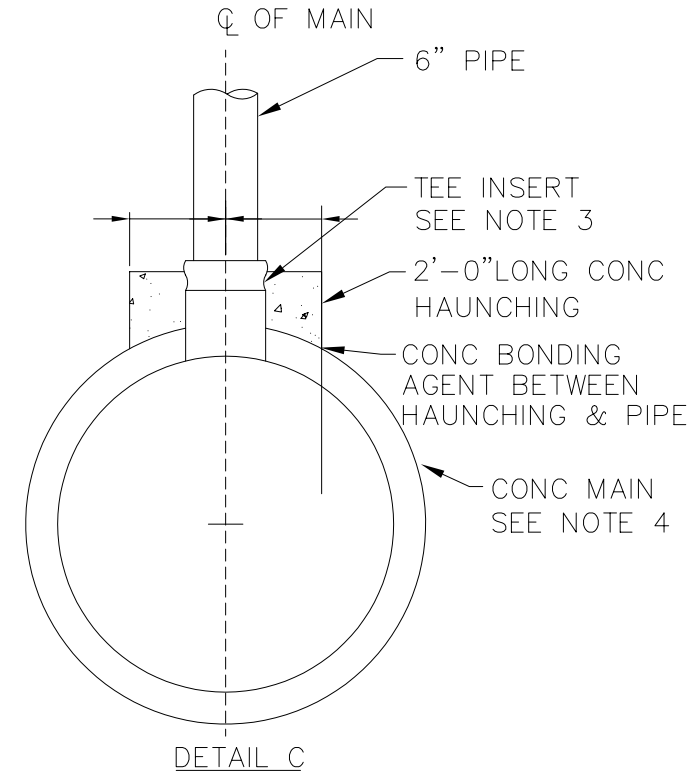
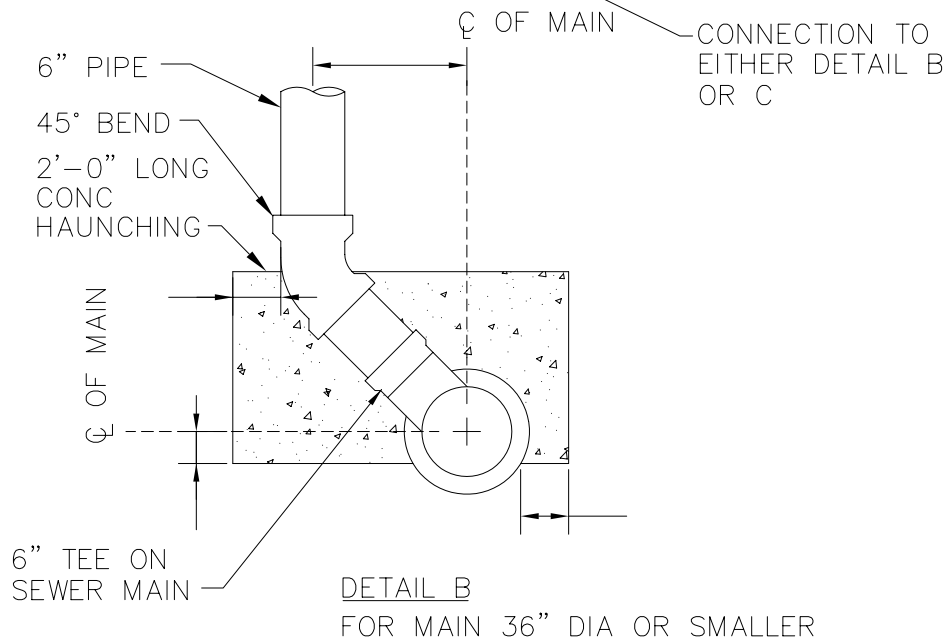

VERTICAL LATERAL/SIDE SEWER CONNECTION

SCALE: NTS

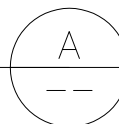

FOR MAIN 42" DIA OR LARGER